

Component Procedures: Suspension Strut / Shock Absorber

Table of Contents

1. Parts and Labor (itype_189)
2. Front Strut Assembly - Components and Components Location (Article 44277)
3. Rear Shock Absorber - Components and Components Location (Article 44284)
4. Front Strut Assembly - Repair Procedures (Article 44278)
5. Rear Shock Absorber - Repair Procedures (Article 44285)

Component Procedures: Suspension Strut / Shock Absorber

Parts and Labor (itype_189)

Parts

Qualifier	Part #	Name	Price	Note
Front Suspension > Suspensio?	54651F2800	3 - Left	239.82	
Front Suspension > Suspensio?	54661F2800	3 - Right	239.82	
Front Suspension > Suspensio?	54651F2800	3 - Left	239.82	
Front Suspension > Suspensio?	54661F3800	3 - Right	424.68	
Front Suspension > Suspensio?	54651F3700	3 - Left	353.27	
Front Suspension > Suspensio?	54661F3700	3 - Right	353.27	
Torsion Axle > Rear Suspensi?	55310F2710	5 - Shock Absorber	168.39	
Torsion Axle > Rear Suspensi?	55310F2710	5 - With 17" Wheels	168.39	
Multi Link > Rear Suspension?	55310F2710	6 - Shock Absorber	168.39	Order By Vehicle Applicati?

Labor

Operation	Qualifier Path	Skill	Std Hrs	Wty Hrs
Remove & Replace	Front Suspension > Suspension Components > St?	B	1.2	0.0
Remove & Replace	Front Suspension > Suspension Components > St?	B	2.2	0.0
Remove & Replace	Multi Link > Rear Suspension > Suspension Com?	C	0.8	0.0
Remove & Replace	Multi Link > Rear Suspension > Suspension Com?	C	1.2	0.0
Remove & Replace	Torsion Axle > Rear Suspension > Suspension C?	C	0.8	0.0
Remove & Replace	Torsion Axle > Rear Suspension > Suspension C?	C	1.1	0.0

Front Strut Assembly - Components and Components Location (Article 44277)

- Components

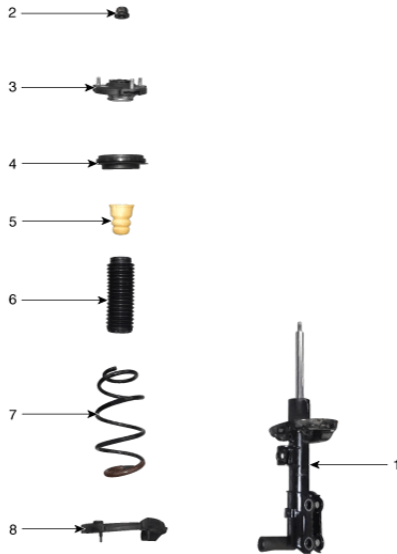

1. Strut assembly 2. Lock nut 3. Insulator 4. Strut bearing & Spring upper pad 5. Bumper rubber 6. Dust cover 7. Coli spring 8. Spring lower pad

Rear Shock Absorber - Components and Components Location (Article 44284)

- Components

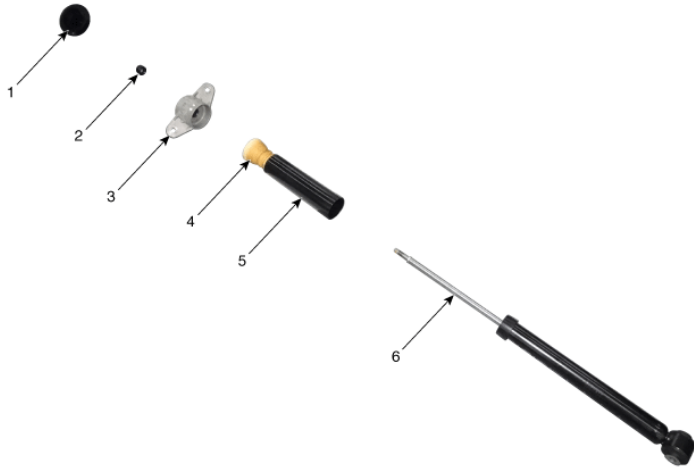

1. Shock absorber dust cap 2. Lock nut 3. Insulator assembly 4. Bumper rubber 5. Dust cover 6. Shock absorber

Front Strut Assembly - Repair Procedures (Article 44278)

- Removal
- Loosen the wheel nuts slightly. Raise the vehicle, and make sure it is securely supported.
- Remove the front wheel and tire (A) from front hub. Tightening torque : 107.9 - 127.5 N.m (11.0 - 13.0 kgf.m, 79.6 - 94.0 lb-ft) Be careful not to damage the hub bolts when removing the front wheel and tire (A).



Be careful not to damage the hub bolts when removing the front wheel and tire (A).

NOTICE

- Be careful not to damage the hub bolts when removing the front wheel and tire (A).
- Loosen the mounting bolt and then remove the brake hose from the strut assembly. Tightening torque : 8.8 - 13.7 N.m (0.9 - 1.4 kgf.m, 6.5 - 10.1 lb-ft)

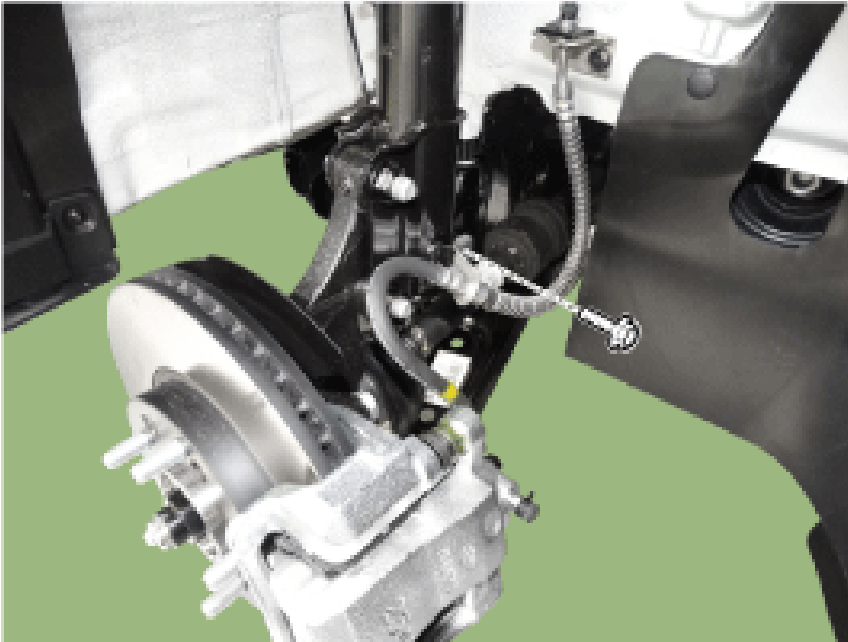

- Loosen the mounting bolt and then remove the wheel speed sensor cable from the strut assembly. Tightening torque : 8.8 - 13.7 N.m (0.9 - 1.4 kgf.m, 6.5 - 10.1 lb-ft)

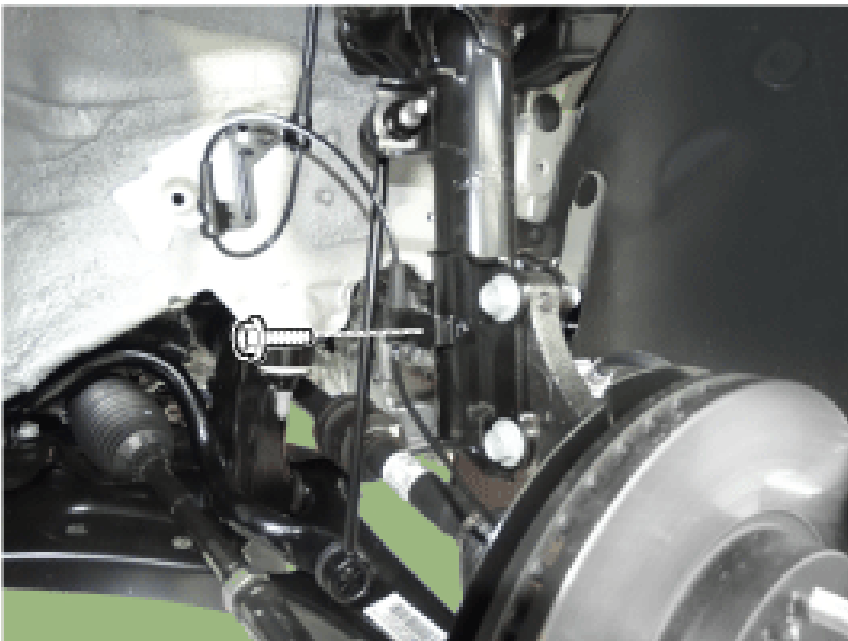

- Disconnect the stabilizer link with the front strut assembly after loosening the nut (A). Tightening torque : 98.1 - 117.7 N.m (10.0 - 12.0 kgf.m, 72.3 - 86.8 lb-ft) When loosening the nut (A), fix the outer hexagon of stabilizer bar link. Be careful not to damage the stabilizer link boots.

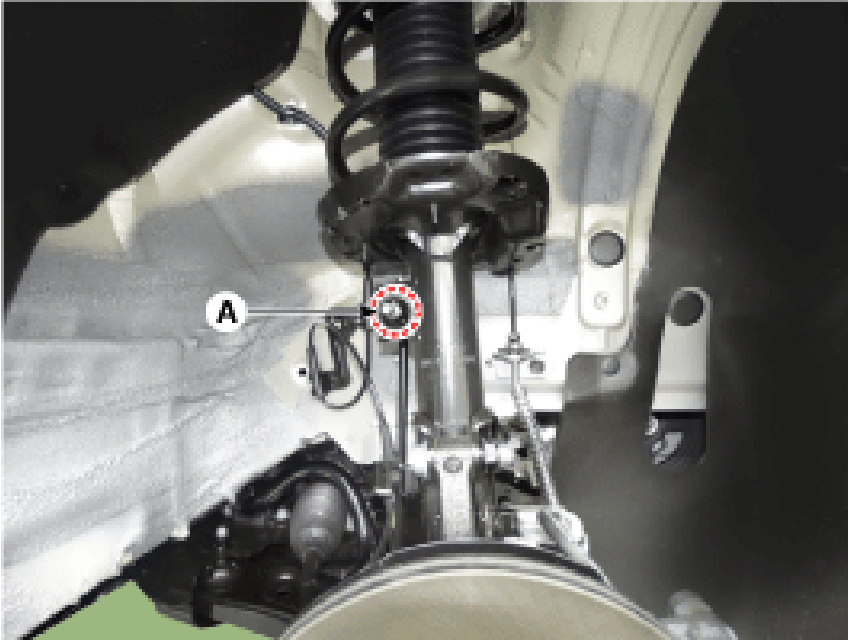

When loosening the nut (A), fix the outer hexagon of stabilizer bar link. Be careful not to damage the stabilizer link boots.

- When loosening the nut (A), fix the outer hexagon of stabilizer bar link. Be careful not to damage the stabilizer link boots.

- Remove the cowl top cover (A). (Refer to Body - "Cowl Top Cover")

- Loosen the upper strut mounting nut (A). Tightening torque : 53.9 - 63.7 N.m (5.5 - 6.5 kgf.m, 39.8 - 47.0 lb-ft)

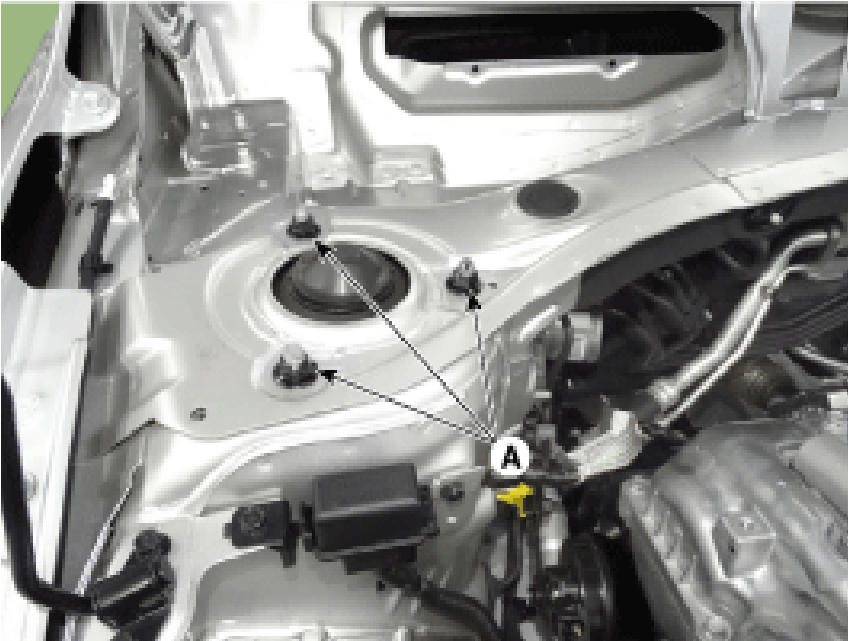

- Disconnect the front strut assembly (A) with the front axle (B) by loosening the bolts ■ nuts. Tightening torque : 156.9 - 176.5 N.m (16.0 - 18.0 kgf.m, 115.7 - 130.2 lb-ft)

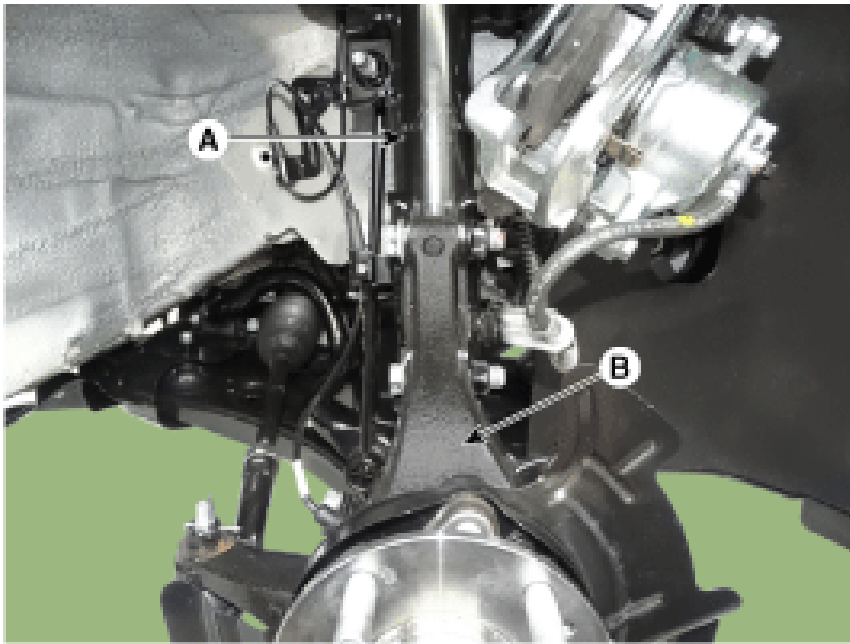

- Install in the reverse order of removal.
- Disassembly

When compressing the coil spring , be cautious as there may be corrosion due to damage to the coil spring painting. In order to avoid such painting damage, compress by putting over the waste hose, etc. (Refer to the picture below.)



Information

- When compressing the coil spring , be cautious as there may be corrosion due to damage to the coil spring painting. In order to avoid such painting damage, compress by putting over the waste hose, etc. (Refer to the picture below.)



- Using the spring compressor, compress the coil spring (A).



- Using the special tool (09546-3X100), remove the self locking nut.



- Remove the insulator, strut bearing, coil spring and dust cover from the strut assembly.

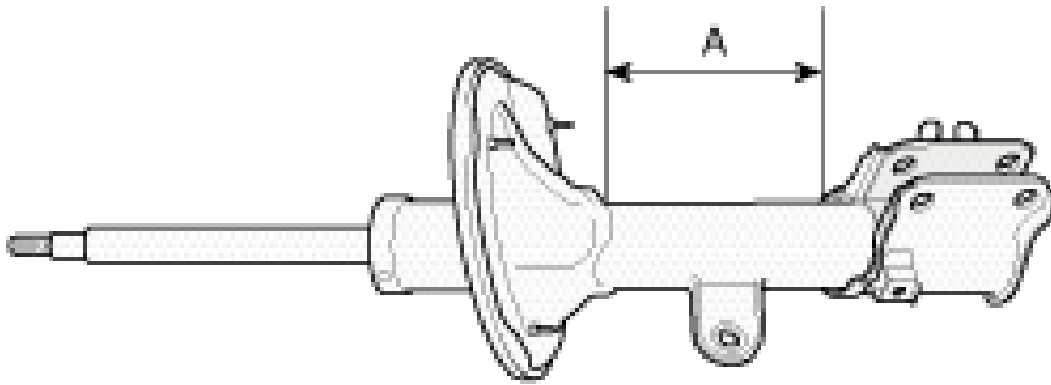

The gas coming out is harmless, but be careful of chips that may fly when drilling. Be sure to wear safety goggles or eye protection when performing this task.



- The gas coming out is harmless, but be careful of chips that may fly when drilling.
 - Be sure to wear safety goggles or eye protection when performing this task.
 - Reassembly
 - Using the special tool (09546-3X100), install the self locking nut. Tightening torque : 98.1 N.m (10.0 kgf.m, 72.3 lb.ft) Do not reuse the self locking nut.
- Do not reuse the self locking nut.

Rear Shock Absorber - Repair Procedures (Article 44285)

- Removal
- Loosen the wheel nut s slightly.
- Raise the vehicle, and make sure it is securely supported.
- Remove the rear wheel and tire (A) from front hub . Tightening torque : 107.9 - 127.5 N.m (11.0 - 13.0 kgf.m, 79.6 - 94.0 lb-ft) Be careful not to damage the hub bolt s when removing the rear wheel and tire (A).

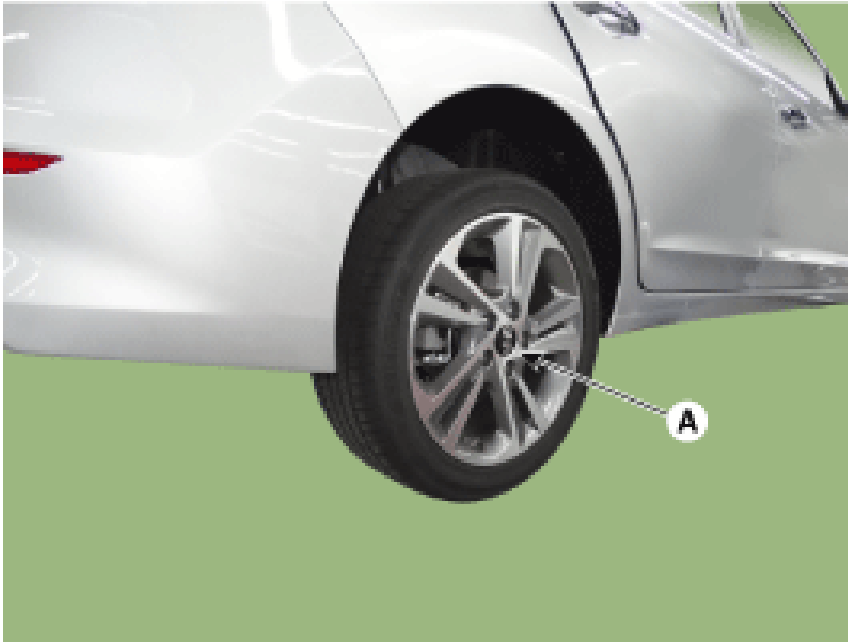

Be careful not to damage the hub bolt s when removing the rear wheel and tire (A).

NOTICE

- Be careful not to damage the hub bolt s when removing the rear wheel and tire (A).
- Remove the rear shock absorber (A) from the frame by loosening the bolt. Tightening torque : 49.0 - 63.7 N.m (5.0 - 6.5 kgf.m, 36.2 - 47.0 lb-ft)



- Loosen the bolt & nut and then remove the rear shock absorber (A) from the torsion beam axle. Tightening torque : 98.1 - 117.7 N.m (10.0 - 12.0 kgf.m, 72.3 - 86.8 lb-ft)

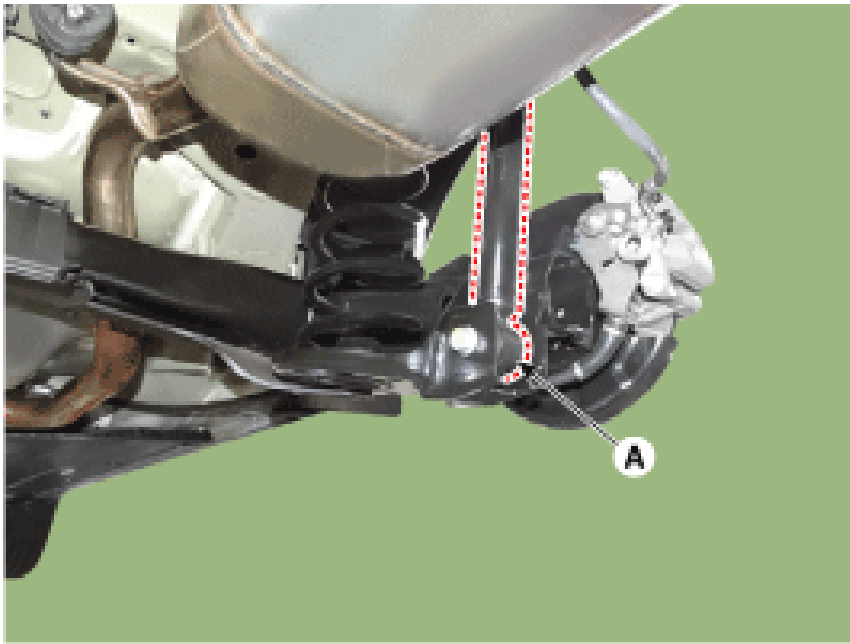

- Install in the reverse order of removal.
- Disassembly
- Remove the lock nut cover (A).

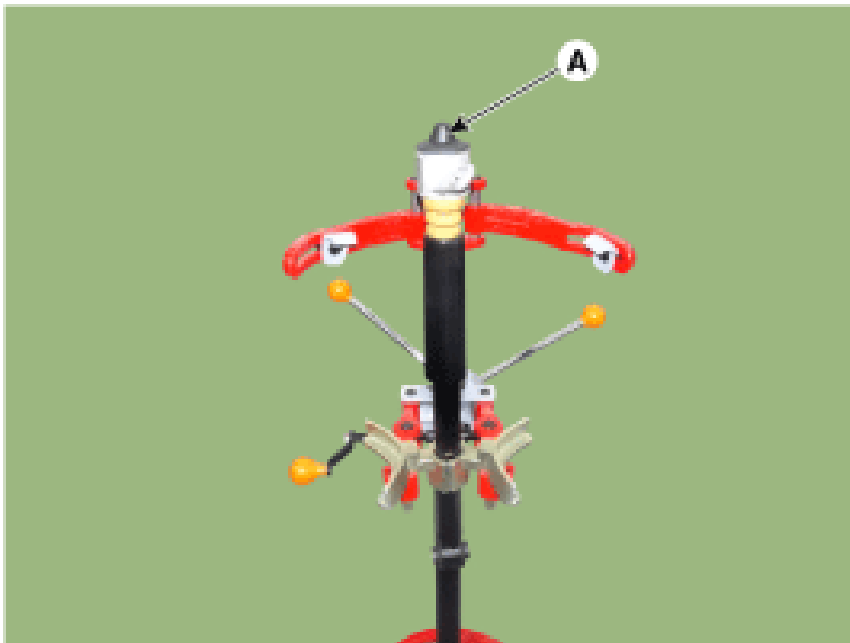

- Using the special tool (09546-3X100), install the self locking nut.



- Separate the bracket assembly (A), bumper rubber (B), dust cover (C), shock absorber (D).

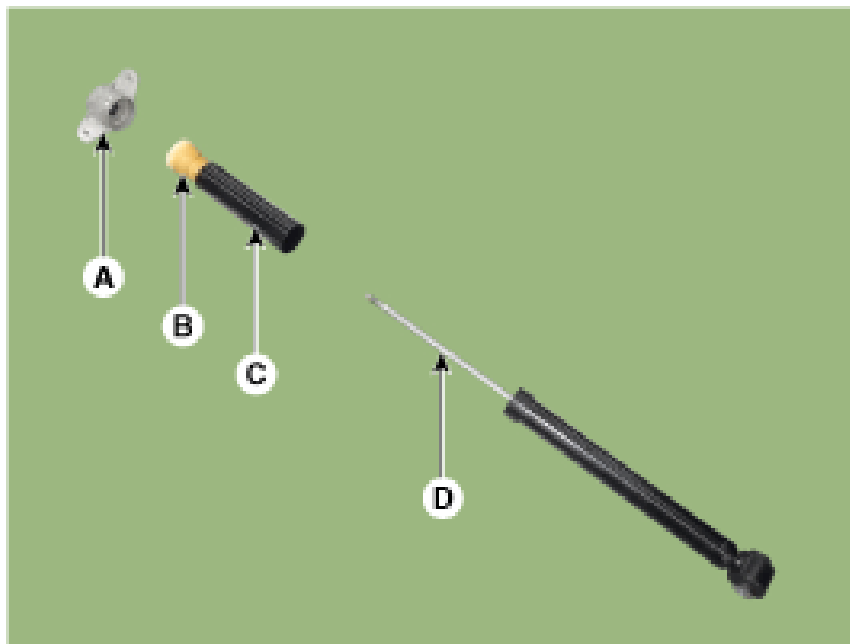

- Disposal
- Remove the strike cap (A) from the shock absorber assembly.
- Remove the gas by Drilling a hole in the inner oil seal. The gas coming out is harmless but be careful of chips that may fly when drilling.

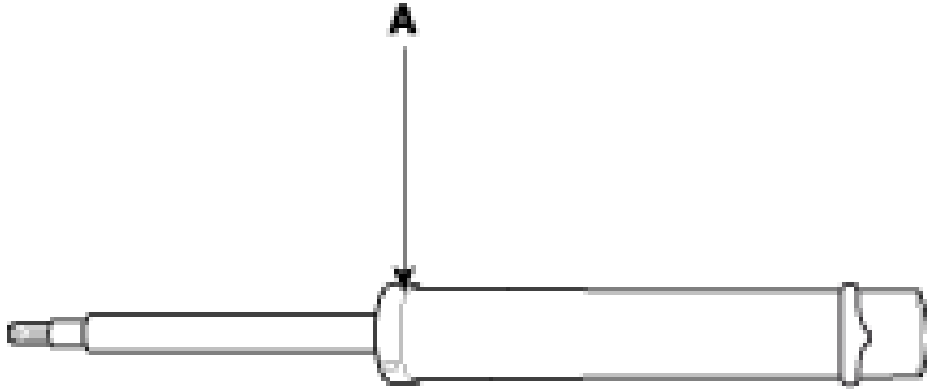

The gas coming out is harmless but be careful of chips that may fly when drilling.



- The gas coming out is harmless but be careful of chips that may fly when drilling.
 - Reassembly
 - To reassembly, reverse the disassembly procedure.
 - Using SST (09546-3X100), install the lock nut. Tightening torque : 19.6 - 24.5 N.m (2.0 - 2.5 kgf.m, 14.5 - 18.1 lb-ft) Do not reuse the self locking nut.
- Do not reuse the self locking nut.
- Install the lock nut cover (A).