

Component Procedures: Cruise Control Module

Table of Contents

1. Smart Cruise Control Unit - Description and Operation (Article 44070)
2. Smart Cruise Control Unit - Schematic Diagrams (Article 44072)
3. Smart Cruise Control Unit - Repair Procedures (Article 44075)
4. Smart Cruise Control Unit - Specifications (Article 44071)

Component Procedures: Cruise Control Module

Smart Cruise Control Unit - Description and Operation (Article 44070)

- Description

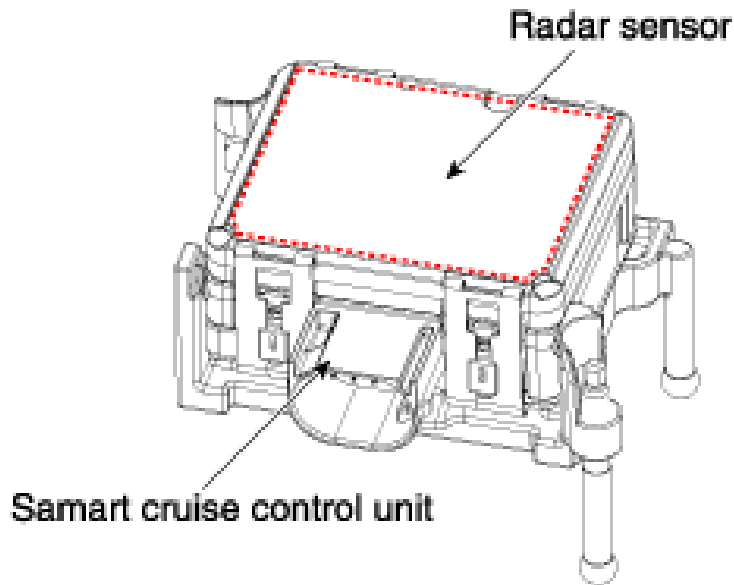

Smart Cruise Control Unit - Schematic Diagrams (Article 44072)

- Circuit Diagram

[Circuit Diagram]

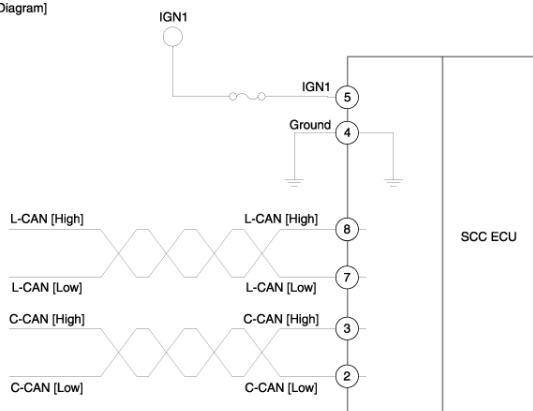

[Connector]



Pin NO	Item
1	-
2	C-CAN [Low]
3	C-CAN [High]
4	Ground
5	IGN1
6	-
7	L-CAN [Low]
8	L-CAN [High]

Smart Cruise Control Unit - Repair Procedures (Article 44075)

- Removal
- Remove the bumper. (Refer to Body - "Front Bumper")
- Disconnect the smart cruise control unit connector (A).
- Remove the smart cruise control unit assembly (B) from vehicle after loosening mounting bolts.

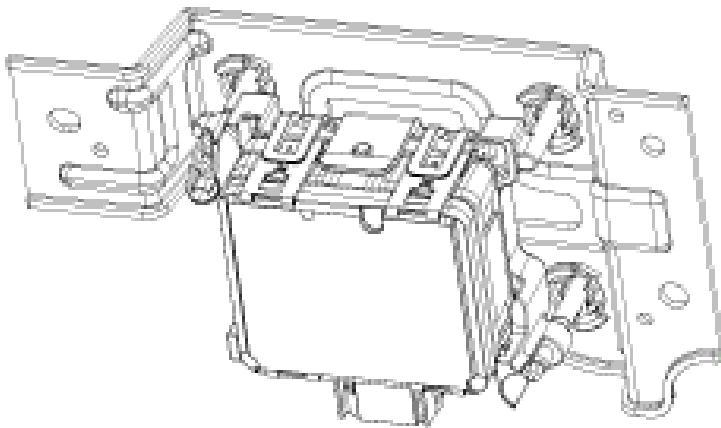
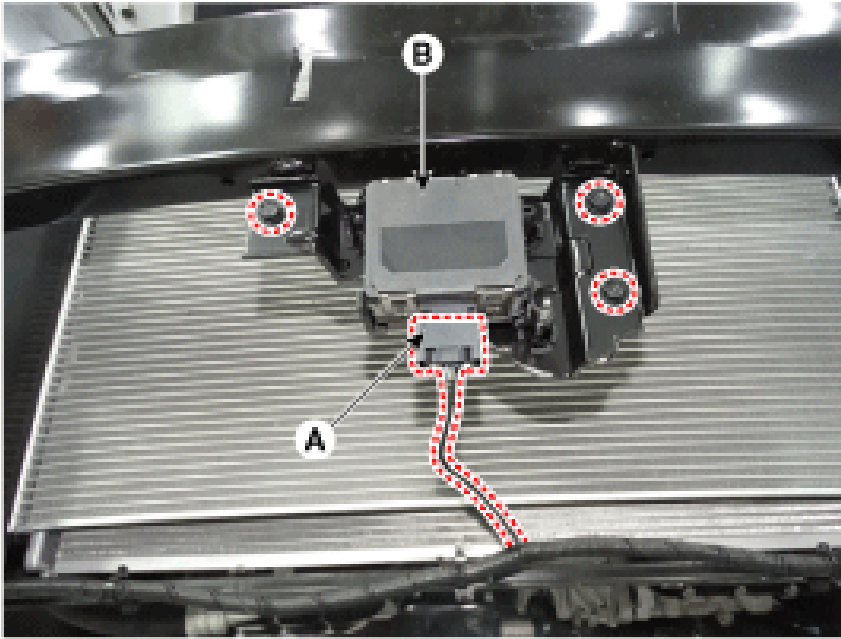

- Installation

- Install in the reverse order of removal. The vertical installation angle of the unit must be within $2^\circ \pm 0.4^\circ$. (not 0 degree) ■ Before installing the bumper onto the vehicle, measure the vertical angle of the unit with a protractor as shown.

The vertical installation angle of the unit must be within $2^\circ \pm 0.4^\circ$. (not 0 degree) ■ Before installing the bumper onto the vehicle, measure the vertical angle of the unit with a protractor as shown.

NOTICE

- The vertical installation angle of the unit must be within $2^\circ \pm 0.4^\circ$. (not 0 degree) ■ Before installing the bumper onto the vehicle, measure the vertical angle of the unit with a protractor as shown.

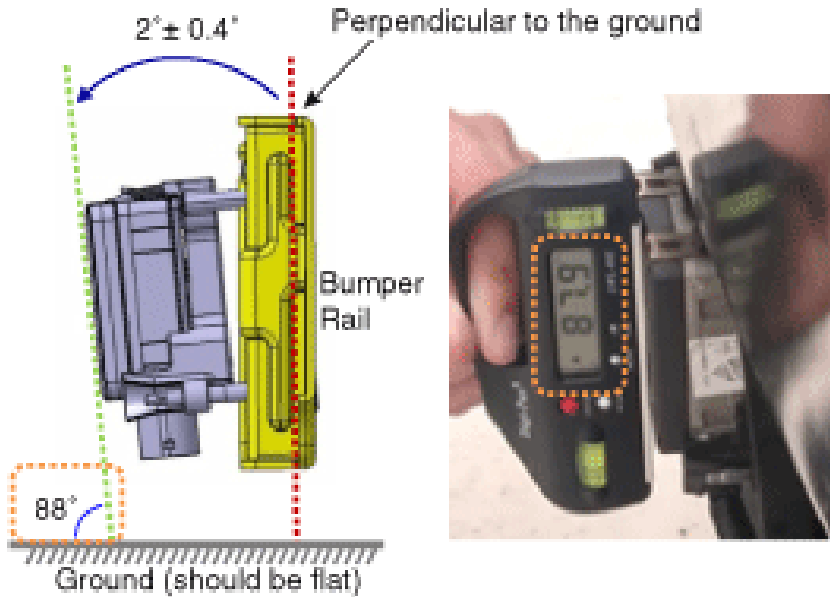

- Align the smart cruise control sensor. (Refer to Engine Electrical System - "Smart Cruise Control(SCC) Alignment")
- Install the bumper cover. (Refer to Body - "Front Bumper Cover")
- Smart Cruise Control (SCC) Sensor Alignment

The sensor must be aligned when; The sensor is reinstalled after removing. A new sensor is installed on a vehicle. The sensor or nearby parts are impacted in a collision. The sensor can not recognize a vehicle ahead.

- The sensor must be aligned when;
- The sensor is reinstalled after removing.
- A new sensor is installed on a vehicle.
- The sensor or nearby parts are impacted in a collision.
- The sensor can not recognize a vehicle ahead.

The sensor can not recognize a vehicle ahead. Remove heavy objects, such as luggage in the trunk, from the vehicle. Remove heavy objects, such as luggage in the trunk, from the vehicle. Check wheel alignment. Check the pollution condition of sensor cover



- Remove heavy objects, such as luggage in the trunk, from the vehicle.
 - Remove heavy objects, such as luggage in the trunk, from the vehicle.
 - Check wheel alignment.
 - Check the pollution condition of sensor cover
- Smart Cruise Control (SCC) Radar Alignment
- Stop the vehicle horizontally at a flat place. Adjustment may not be accurate if the installation surface height and angle of the vehicle and reflector are different. Perform in an area with minimum clearance of 8m front, 4m sides, and 1.2m above the vehicle. Remove heavy objects from inside of the vehicle (seating area and trunk). Ensure that all tires are filled with spec air pressure. Remove objects (metal plates, resins, etc.) that may cause electric signal interference from the area where sensor alignment is performed. Be sure that the vehicle is not moved and free from vibration when performing sensor alignment (getting in/out or opening/closing doors). Check that radiator grill and sensor cover is not dirty. Check that the wheel alignment is normal. Do not turn OFF the power when performing sensor alignment. Power supplied to the radar sensor must be between 9V-16V. Temperature in the area where sensor alignment is performed must be between -30-60°C.

Adjustment may not be accurate if the installation surface height and angle of the vehicle and reflector are different. Perform in an area with minimum clearance of 8m front, 4m sides, and 1.2m above the vehicle. Remove heavy objects from inside of the vehicle (seating area and trunk). Ensure that all tires are filled with spec air pressure. Remove objects (metal plates, resins, etc.) that may cause electric signal interference from the area where sensor alignment is performed. Be sure that the vehicle is not moved and free from vibration when performing sensor alignment (getting in/out or opening/closing doors). Check that radiator grill and sensor cover is not dirty. Check that the wheel alignment is normal. Do not turn OFF the power when performing sensor alignment. Power supplied to the radar sensor must be between 9V-16V. Temperature in the area where sensor alignment is performed must be between -30-60°C.

- Adjustment may not be accurate if the installation surface height and angle of the vehicle and reflector are different.
- Perform in an area with minimum clearance of 8m front, 4m sides, and 1.2m above the vehicle.
- Remove heavy objects from inside of the vehicle (seating area and trunk).
- Ensure that all tires are filled with spec air pressure.
- Remove objects (metal plates, resins, etc.) that may cause electric signal interference from the area where sensor alignment is performed.
- Be sure that the vehicle is not moved and free from vibration when performing sensor alignment (getting in/out or opening/closing doors).
- Check that radiator grill and sensor cover is not dirty.
- Check that the wheel alignment is normal.
- Do not turn OFF the power when performing sensor alignment.
- Power supplied to the radar sensor must be between 9V-16V.
- Temperature in the area where sensor alignment is performed must be between -30-60°C.

[Work Area Specification]

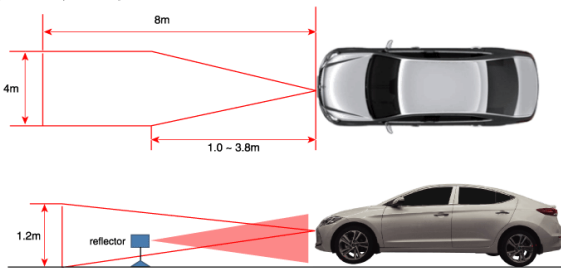

[Leveling: Installation surface of the vehicle and the reflector must be evenly levelled.]



[Inappropriate Location - Example]

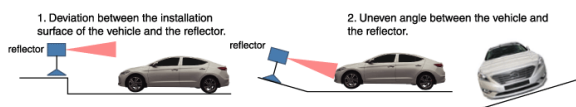

- Mark the center point of emblem (A) and the center point on top of wind glass (B).

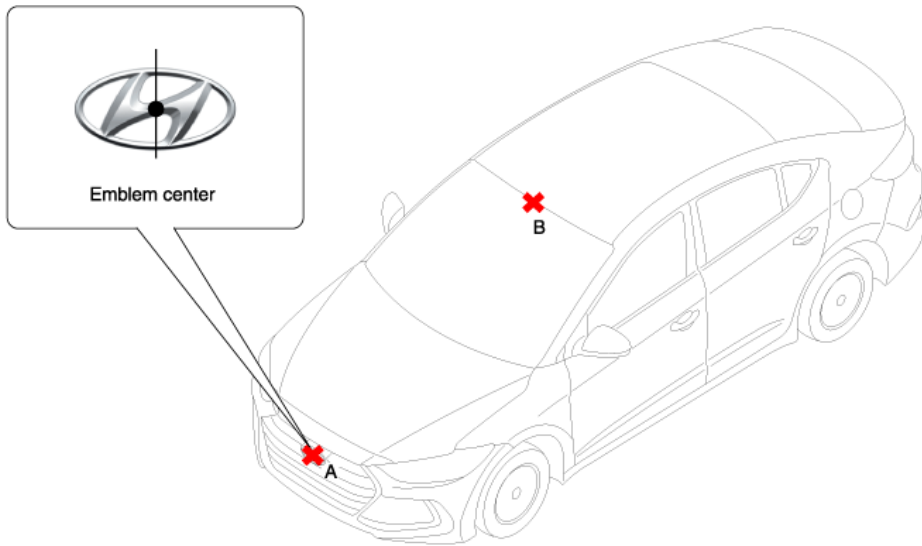

- Connect the SCC Calibration Laser (SST No. : 09964-C1200) to the Tri-Pod (SST No. : 09964-C1300).



- Match the vertical line of laser to (A) and (B) using the SCC calibration laser pointer.

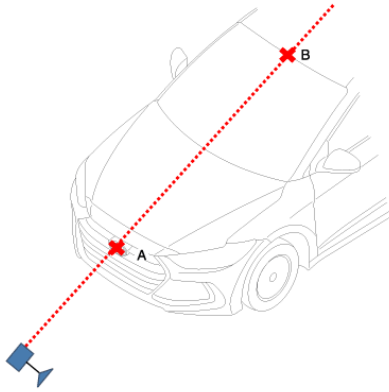
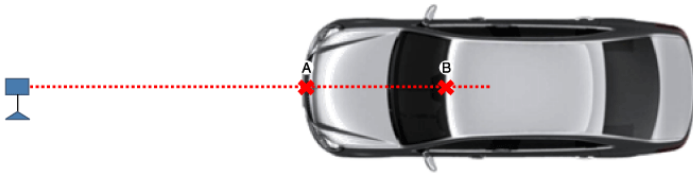

- Mark (C) located in 1.0-3.8m from (A) in front of the vehicle.

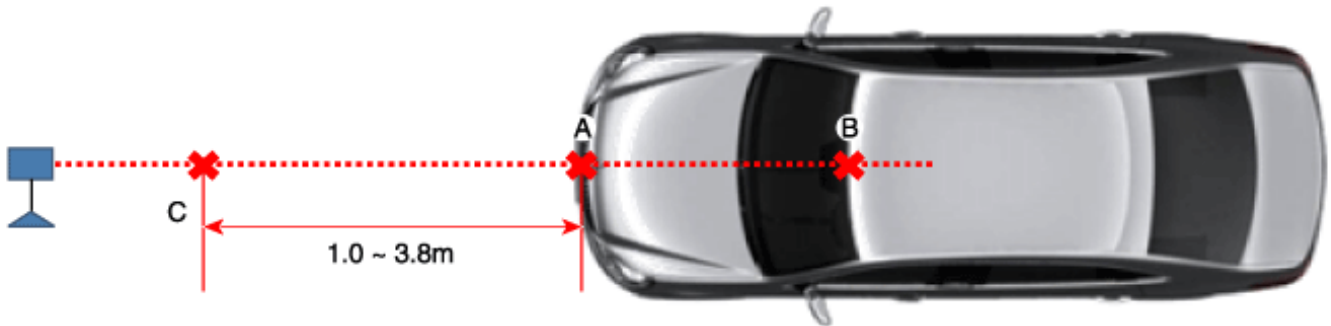

- Disconnect the SCC Calibration Laser (SST No. : 09964-C1200) from the Tri-Pod (SST No. : 09964-C1300).
- Align the vertical weight of the with the point (C).
- Connect the reflector (SST No. : 09964-C1100) to the tripod (SST No. : 09964-C1300) and set the reflector center height to 344mm.

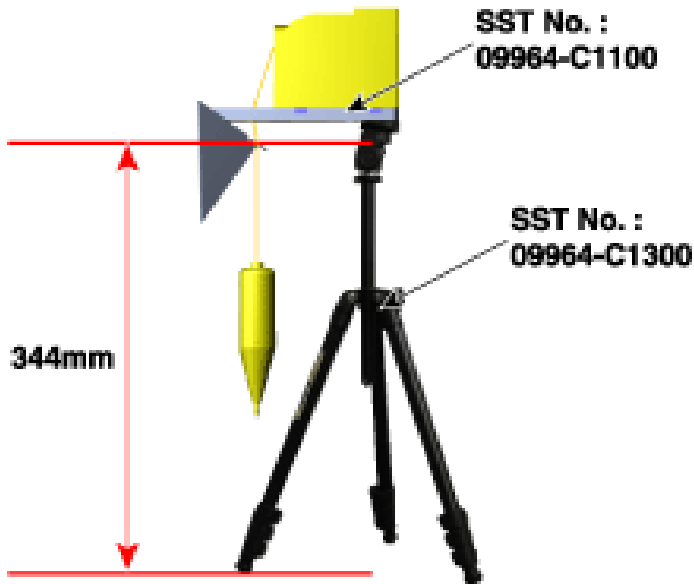

- Set the reflector horizontal using the leveler which is built in the tripod (SST No. : 09964-C1300). Balance the level so that the bubble in the level is set between the spec lines.



Balance the level so that the bubble in the level is set between the spec lines.

- Balance the level so that the bubble in the level is set between the spec lines.
- Remove the vertical weight. Visually check that the reflecting side of the reflector is levelled with the front of the vehicle.

Visually check that the reflecting side of the reflector is levelled with the front of the vehicle.

- Visually check that the reflecting side of the reflector is levelled with the front of the vehicle.
- Check again the radar sensor and the surface of front bumper for the following items with the eyes. Make sure that there is no debris, or reflecting object on the surface of the radar. Make sure that there is no debris, or reflecting object on the radiator grill.

Make sure that there is no debris, or reflecting object on the surface of the radar. Make sure that there is no debris, or reflecting object on the radiator grill.

- Make sure that there is no debris, or reflecting object on the surface of the radar.
 - Make sure that there is no debris, or reflecting object on the radiator grill.
 - Connect the GDS to the DLC of the vehicle and start sensor alignment. If the engine is running, the vibration may cause inaccurate sensor alignment, so perform sensor alignment in IG ON mode.
- If the engine is running, the vibration may cause inaccurate sensor alignment, so perform sensor alignment in

IG ON mode.

- If the engine is running, the vibration may cause inaccurate sensor alignment, so perform sensor alignment in IG ON mode.

- After correctly selecting the vehicle model, select "SCC Alignment" from the auxiliary functions in GDS Menu.

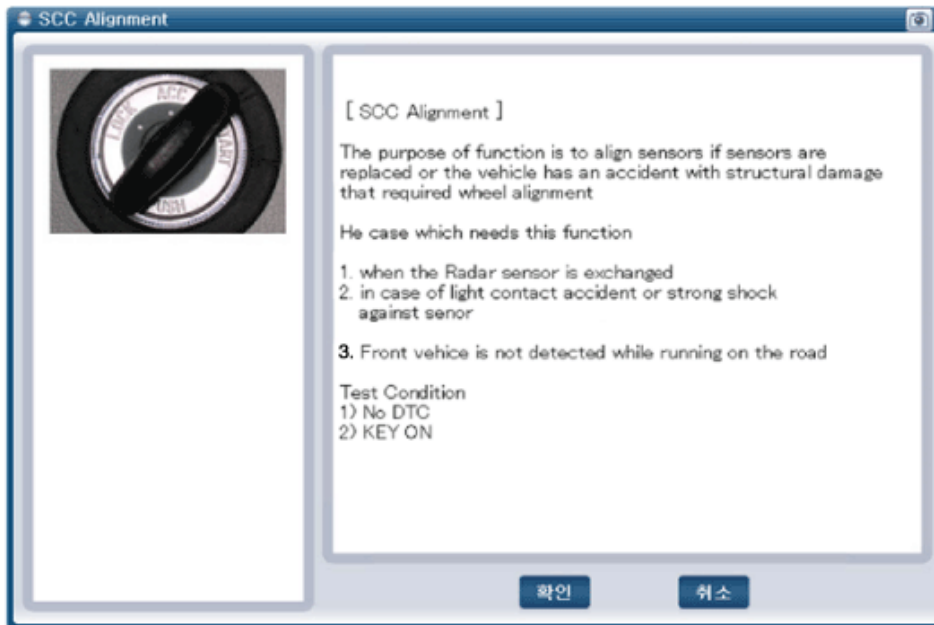

- Perform sensor alignment by following the directions shown in the GDS monitor.

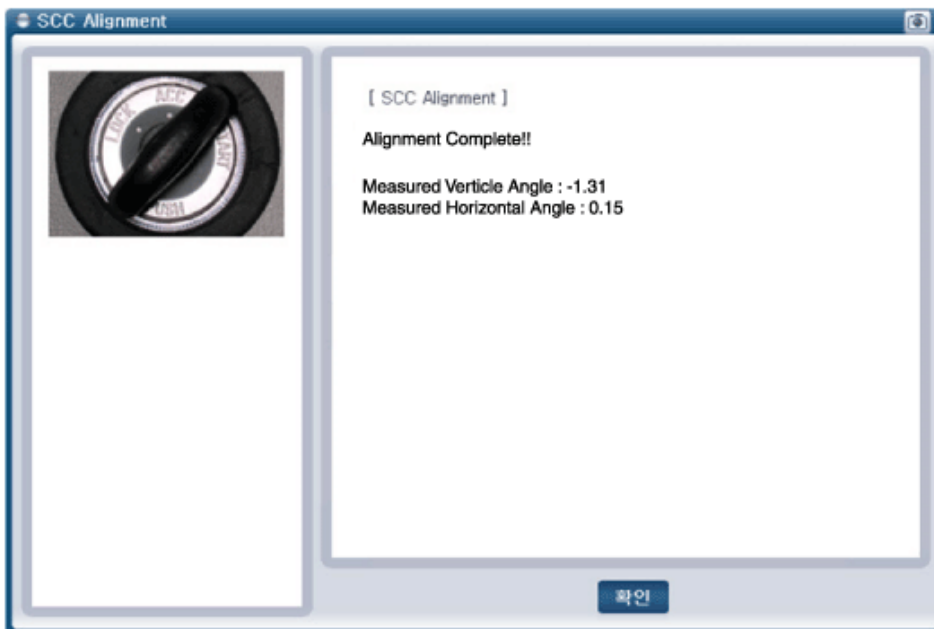

- In case of sensor alignment failure, check the alignment conditions. Turn the ignition key OFF, then reperform the sensor alignment procedure.

- Inspection

- Check the bumper appearance and accidents. (Visual appearance of the vehicle, Maintenance and bumper replacement history) ⇨ If the vehicle has been crashed, SCC mounting part is highly likely to be twisted.

- Check whether the radar sensor cover of the bumper is dirty. ⇨ If the cover is dirty, SCC is highly likely to be released by the foreign substance during operation.

- After engine starting, check SCC warning message in the cluster and DTC code. (Refer to DTC guide)

Smart Cruise Control Unit - Specifications (Article 44071)

- Specification

Item Specification

Power supply (V) 12
Operation voltage (V) 9 - 16