

Component Procedures: Headlamp

Table of Contents

1. Parts and Labor (itype_189)
2. Adaptive Front-Lighting System (AFS) - Description and Operation (Article 44681)
3. Adaptive Front-Lighting System (AFS) Unit - Description and Operation (Article 44683)
4. Auto Lighting Control System - Description and Operation (Article 44661)
5. Auto Lights - Service Tips (Article 42592)
6. Head Lamps - Service Tips (Article 42493)
7. Headlights - Autolamps Circuit (Article 12175)
8. Headlights - Headlamps Circuit (Article 12125)
9. Adaptive Front-Lighting System (AFS) - Components and Components Location (Article 44678)
10. Auto Lighting Control System - Components and Components Location (Article 44658)
11. Adaptive Front-Lighting System (AFS) - Repair Procedures (Article 44682)
12. Adaptive Front-Lighting System (AFS) Unit - Repair Procedures (Article 44684)
13. Headlamps - Repair Procedures (Article 44649)
14. Adaptive Front-Lighting System (AFS) - Specifications (Article 44677)
15. Auto Lighting Control System - Specifications (Article 44657)
16. All New Technical Service Bulletins (itype_432)
17. All Technical Service Bulletins (itype_100)
18. Auto Lights - Service Tips (Article 42593)
19. Head Lamps - Service Tips (Article 42494)
20. Erratic Operation (itype_132)
21. Miscellaneous Information (itype_111)
22. OEM Policies and Procedures (itype_120)
23. Service Campaigns (itype_108)

Component Procedures: Headlamp

Parts and Labor (itype_189)

Parts

Qualifier	Part #	Name	Price	Note
Headlamps > Composite Assemb?	92101F2840	With Sport	2174.15	
Headlamps > Composite Assemb?	92101F2740	Korea Built	2239.31	
Headlamps > Composite Assemb?	92101F2760	Us Built	2239.31	
Headlamps > Composite Assemb?	92101F2640	With Led Drl	894.84	
Headlamps > Composite Assemb?	92101F2540	Without Led Drl	714.32	
Headlamps > Composite Assemb?	92101F3510	With Led Drl	599.11	
Headlamps > Composite Assemb?	92101F3500	Without Led Drl	642.81	
Headlamps > Composite Assemb?	92102F2840	With Sport	2239.31	
Headlamps > Composite Assemb?	92102F2740	Korea Built	2239.31	
Headlamps > Composite Assemb?	92102F2760	Us Built	2106.58	
Headlamps > Composite Assemb?	92102F2640	With Led Drl	884.52	
Headlamps > Composite Assemb?	92102F2540	Without Led Drl	714.32	
Headlamps > Composite Assemb?	92102F3510	With Led Drl	884.52	
Headlamps > Composite Assemb?	92102F3500	Without Led Drl	714.32	

Labor

Operation	Qualifier Path	Skill	Std Hrs	Wty Hrs
Align	Headlamps > Headlamp, Align	B	0.4	0.0
Remove & Replace	Headlamps > Headlamp, R&R > One Side	B	1.7	0.0
Remove & Replace	Headlamps > Headlamp, R&R > Both Sides	B	2.0	0.0

Adaptive Front-Lighting System (AFS) - Description and Operation (Article 44681)

- Description

Adaptive Front-Lighting System (AFS)

Component of AFS

- Input part : It is provided that information of speed sensor, height sensor and so on related to condition of vehicle.

- Control part (AFS Unit) : It controls Output part by analyzing/judging Input signal.

- Output part : It drive Low beam of H/Lamp to left/right side optimum beam pattern according to output control signal of AFS Unit.

Main function of AFS

Content Description

1 Dynamic Bending (Swivelling) Providing optimum beam pattern in the curve road Enhanced visibility in the curve road Drive Low beam to left / right side

- Providing optimum beam pattern in the curve road

- Enhanced visibility in the curve road

- Drive Low beam to left / right side

2 Fail-safe Fail-safe reaction while detecting system failure and malfunction Detecting signal / communication error for Swivelling Detecting system failure

- Fail-safe reaction while detecting system failure and malfunction

- Detecting signal / communication error for Swivelling

- Detecting system failure

Advantage of AFS

1 Enhanced stability Visibility Guarantee In case of curve road According to vehicle Speed/Steering angle, speed/angle of Swivel actuator is automatically controlled to provide optimum beam pattern Fail-safe reaction application for Driver on opposite side road →In case error communication,automatically return initial position of Swivel actuator

- Visibility Guarantee In case of curve road

- According to vehicle Speed/Steering angle, speed/angle of Swivel actuator is automatically controlled to provide optimum beam pattern

- Fail-safe reaction application for Driver on opposite side road →In case error communication,automatically return initial position of Swivel actuator

- 2 Enhanced convenience AFS operating application by driver's selection(AFS Off switch) Providing Diagnostic function for detecting system failure and malfunction and check up data information (by using Diagnostic equipment) Reduced wiring-harness by Applying CAN/LIN communication in vehicle Fun Driving Function : Swivelling of Low beam → Increasing driver's pride
- AFS operating application by driver's selection(AFS Off switch)
- Providing Diagnostic function for detecting system failure and malfunction and check up data information (by using Diagnostic equipment)
- Reduced wiring-harness by Applying CAN/LIN communication in vehicle
- Fun Driving Function : Swivelling of Low beam → Increasing driver's pride
- Operation
- Component
- AFS Unit (A)

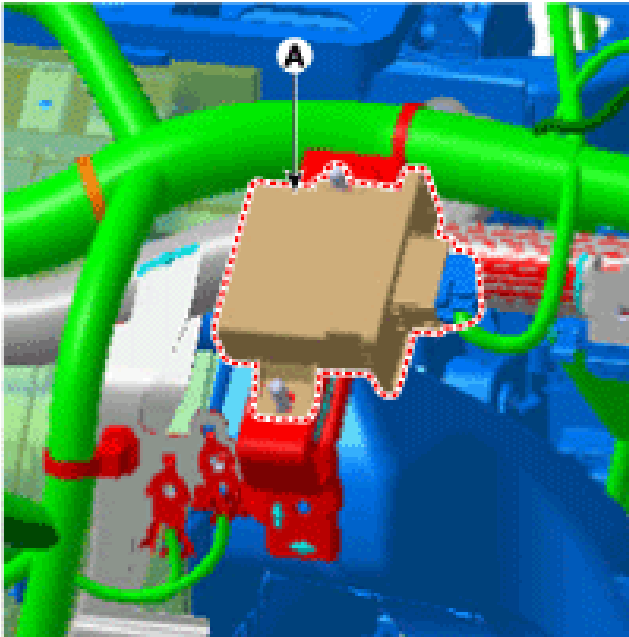

- General System initialization, In case of input Engine signal (AFS ECU /Swivelling motor) AFS operate normally ,only under turning low beam switch on. Providing Tel-tale function of AFS (display 'AFS' on dashboard). In case of system failure, display light on 'AFS' on dashboard

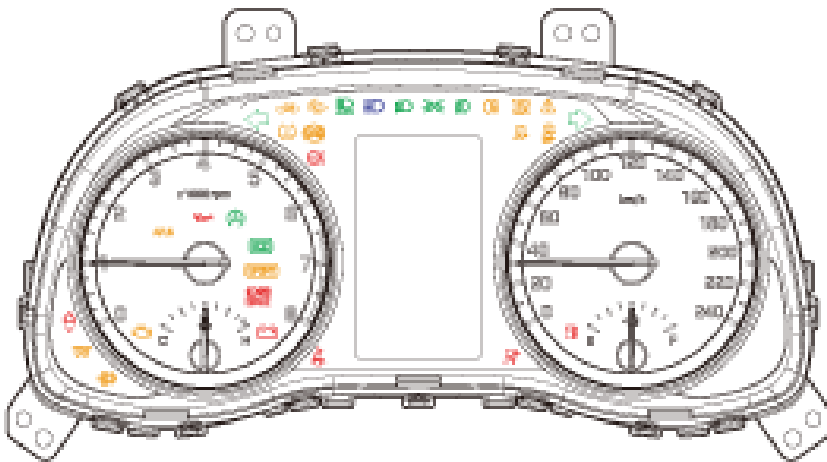

- Main function Swivelling function Control the shield drum to change the beam pattern
- Swivelling Motor (A)
- General communicate AFS Unit through LIN protocol Robust control to Disturbance Doesn't work out of rated

voltage range.

- Main function & Rating Drive Low beam to left / right side Fail-safe function : In case of detecting malfunction or system failure , drive to secure position

Adaptive Front-Lighting System (AFS) Unit - Description and Operation (Article 44683)

- Description
AFS Unit (ECU)

Auto Lighting Control System - Description and Operation (Article 44661)

- Description
- Do not add another device on top of this device.
- Be sure to switch to manual during poor visibility climate, such as fog, heavy rain, or cloudy weather.
- Illumination intensity in an actual vehicle is not always constant, and lamp ON/OFF time may vary depending on the climate, season, and surrounding environment.
- Use this system only during sunrise and sunset period, and manually control lamp ON/OFF for general conditions.
- Error may occur if light block coating that may change interior illumination is applied.

Auto Lights - Service Tips (Article 42592)

Auto Lights	Service Tips (1)																						
<p>Circuit Description</p> <p>To operate the Auto lights, the ignition switch must be in the ON position or higher. Lights switch Auto mode automatically controls the head lamp and tail lamp depends on driving condition (rain, snow, night, tunnel) using the auto lights & photo sensor which detects brightness of surrounding the vehicle.</p> <p>■ Caution</p> <ol style="list-style-type: none">1. Do not place anything over the sensor.2. In fog, rain or cloudy weather, use manual mode.3. Auto lights ON/OFF time will changed depend on surrounding environment (weather, climate).4. Use this mode for sunrise and sunset. Control the lamp ON/OFF switch manually.5. If the glass of the vehicle is filmed or tinted, it may cause the sensor malfunction. <p>■ Dimmer/ Passing Switch : LOW</p> <p>In the light switch AUTO position, when the dimmer/passing switch is placed in LOW, BCM received signal and transmit it to IPS control module through the CAN communication. IPS control module control ARISU (4CH) to turn on the head lamp (LOW). Result of control and diagnosis is send to BCM through the CAN communication.</p> <p>■ Dimmer/ Passing Switch : HIGH</p> <p>In the light switch AUTO position, when the dimmer/passing switch is placed in HIGH, BCM received signal and transmit it to IPS control module and cluster instrument through the CAN communication.</p> <p>MICOM in cluster instrument turn on the high beam indicator, and IPS control module control ARISU (4CH) to turn on the head lamp (HIGH). Result of control and diagnosis is send to BCM through the CAN communication.</p>	<p>■ Multifunction Switch Inspection</p> <p>When each switch is pressed, check the electricity flow between multi-function switch connector and grounding, and if the electricity does not match the specification, replace the switch.</p> <table border="1"><thead><tr><th>Switch</th><th>Switch position</th><th>Switch position</th><th>Resistance (Ω , ± 3.5%)</th></tr></thead><tbody><tr><td rowspan="3">Dimmer & Passing switch</td><td>OFF</td><td rowspan="3">9-13</td><td>—</td></tr><tr><td>PASSING</td><td>910</td></tr><tr><td>DIMMER</td><td>2910</td></tr><tr><td rowspan="4">Light switch</td><td>OFF</td><td rowspan="4">9-14</td><td>680</td></tr><tr><td>AUTO</td><td>—</td></tr><tr><td>TAIL LAMP</td><td>1680</td></tr><tr><td>HLAMP (Low)</td><td>5580</td></tr></tbody></table>	Switch	Switch position	Switch position	Resistance (Ω , ± 3.5%)	Dimmer & Passing switch	OFF	9-13	—	PASSING	910	DIMMER	2910	Light switch	OFF	9-14	680	AUTO	—	TAIL LAMP	1680	HLAMP (Low)	5580
Switch	Switch position	Switch position	Resistance (Ω , ± 3.5%)																				
Dimmer & Passing switch	OFF	9-13	—																				
	PASSING		910																				
	DIMMER		2910																				
Light switch	OFF	9-14	680																				
	AUTO		—																				
	TAIL LAMP		1680																				
	HLAMP (Low)		5580																				

Head Lamps - Service Tips (Article 42493)

Circuit Description

To operate the head lamp, the ignition switch must be in the IG2 position or higher. Rotate the light switch of the multifunction switch to the HEAD position and determine LOW/HIGH of the dimmer/passing switch. Generally, the dimmer/passing switch is placed in the LOW position.

■ Dimmer/ Passing Switch : LOW

In the light switch HEAD position, when the dimmer/passing switch is placed in LOW, BCM received signal and transmit it to IPS control module through the CAN communication. IPS control module control ARISU (4CH) to turn on the head lamp (LOW). Result of control and diagnosis is send to BCM through the CAN communication.

■ Dimmer/ Passing Switch : HIGH

In the light switch HEAD position, when the dimmer/passing switch is placed in HIGH, BCM received signal and transmit it to IPS control module and cluster instrument through the CAN communication. MICOM in cluster instrument turn on the high beam indicator, and IPS control module control ARISU (4CH) to turn on the head lamp (HIGH). Result of control and diagnosis is send to BCM through the CAN communication.

■ Dimmer/ Passing Switch : PASS

It can be operated regardless of the light switch HEAD position. Pull the dimmer/passing switch toward the driver 2-3 times to warn other vehicles and to turn on the high beam indicator light on the instrument cluster and head lamp.

■ Control Function - CAN FAIL

If CAN is failed and ignition switch is ON, Smart junction block turn ON the head lamp (LOW) by force for driver safety.

■ Multifunction Switch Inspection

When each switch is pressed, check the electricity flow between multi-function switch connector and grounding, and if the electricity does not match the specification, replace the switch.

Switch	Switch position	Switch position	Resistance (Ω , ± 3.5%)
Dimmer & Passing switch	OFF	9-13	—
	PASSING		910
	DIMMER		2910
Light switch	OFF	9-14	680
	AUTO		—
	TAIL LAMP		1680
	HLAMP (Low)		5580

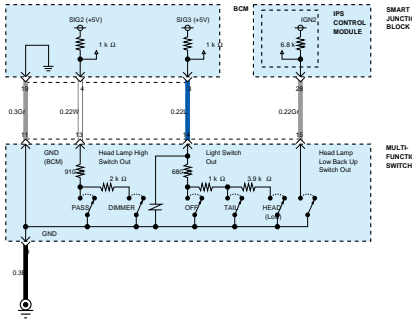

Headlights - Autolamps Circuit (Article 12175)

Headlights - Autolamps Circuit

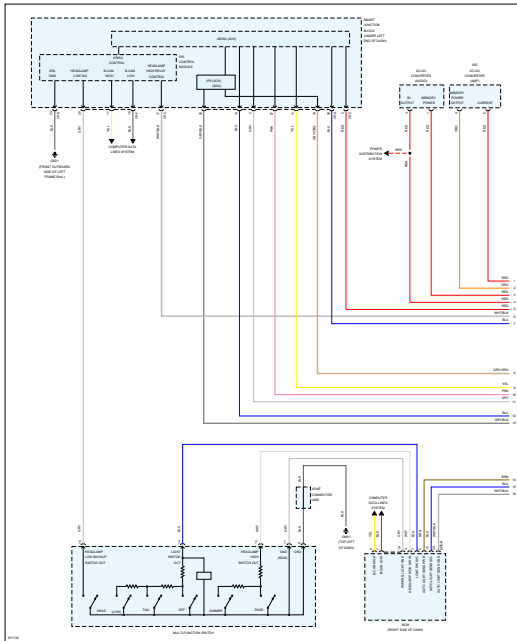

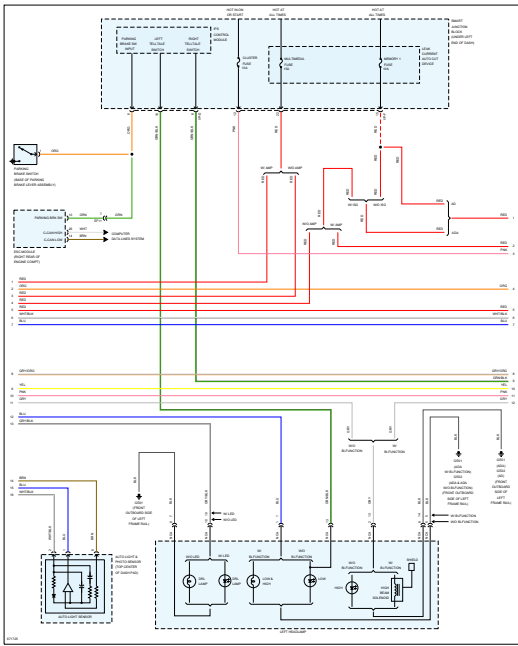

Page 3 of 3

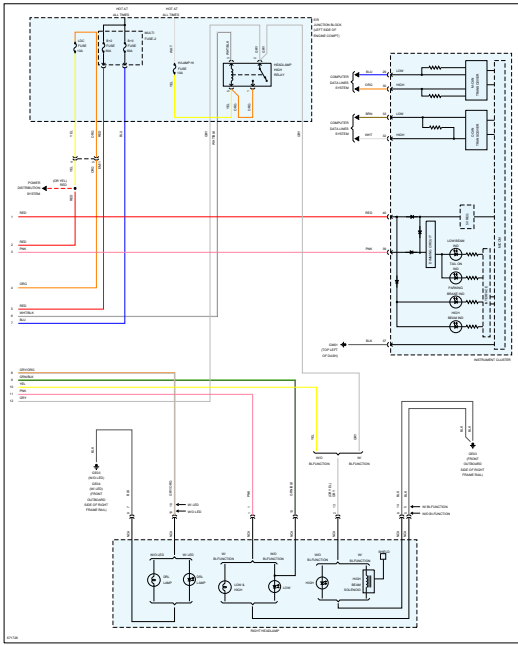

Headlights - Headlamps Circuit (Article 12125)

Headlights - Headlamps Circuit

Page 1 of 3

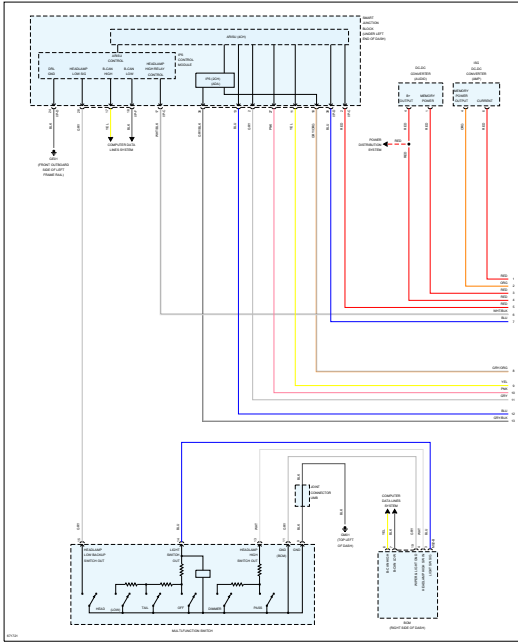

Page 2 of 3

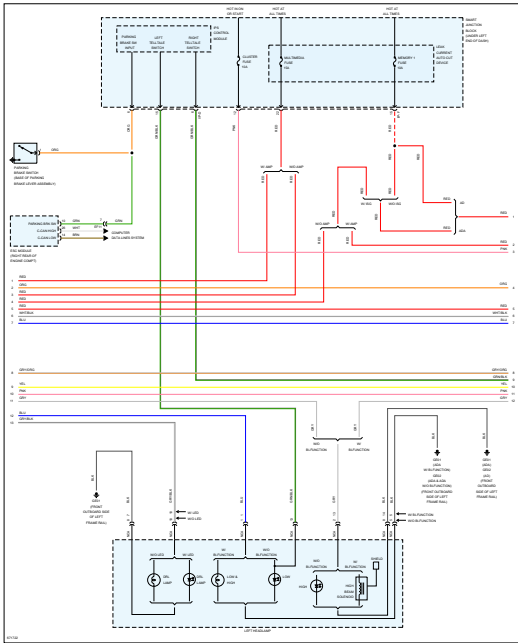

Page 3 of 3

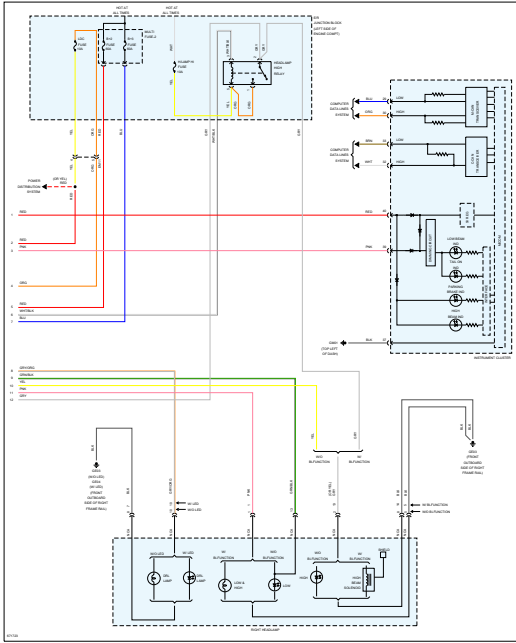

Adaptive Front-Lighting System (AFS) - Components and Components Location (Article 44678)

- Components

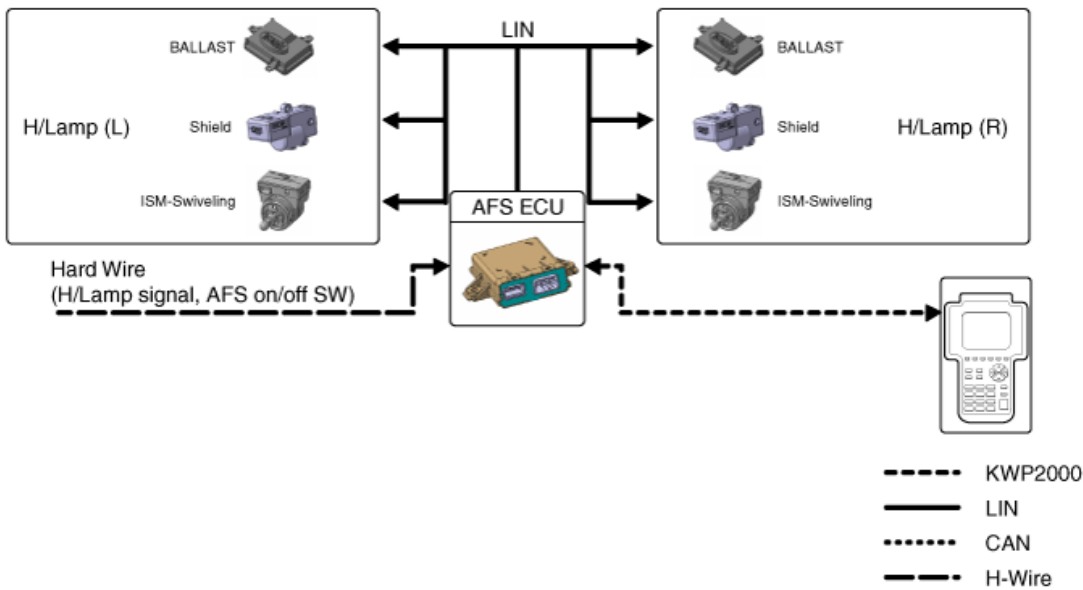

Auto Lighting Control System - Components and Components Location (Article 44658)

- Component Location

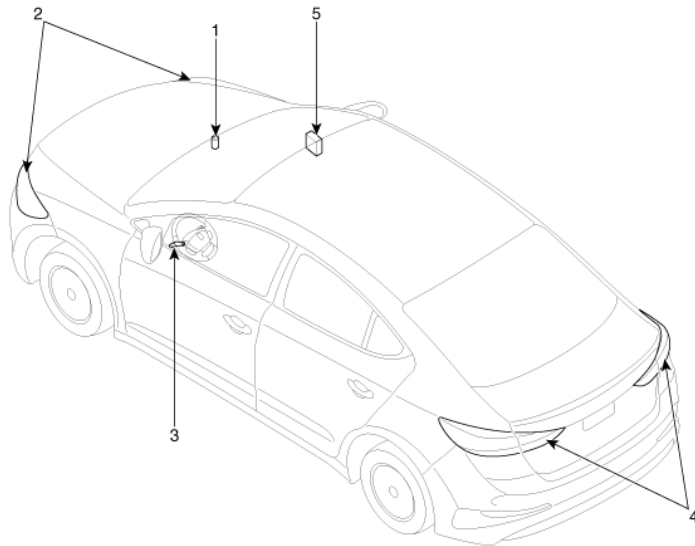

1. Auto light sensor 2. Head lamps 3. Lighting switch (Auto) 4. Tail lamps 5. BCM (Body Control Module)

Adaptive Front-Lighting System (AFS) - Repair Procedures (Article 44682)

- Inspection
- Download Parameter
- Select " AFS " menu after selecting a vehicle.

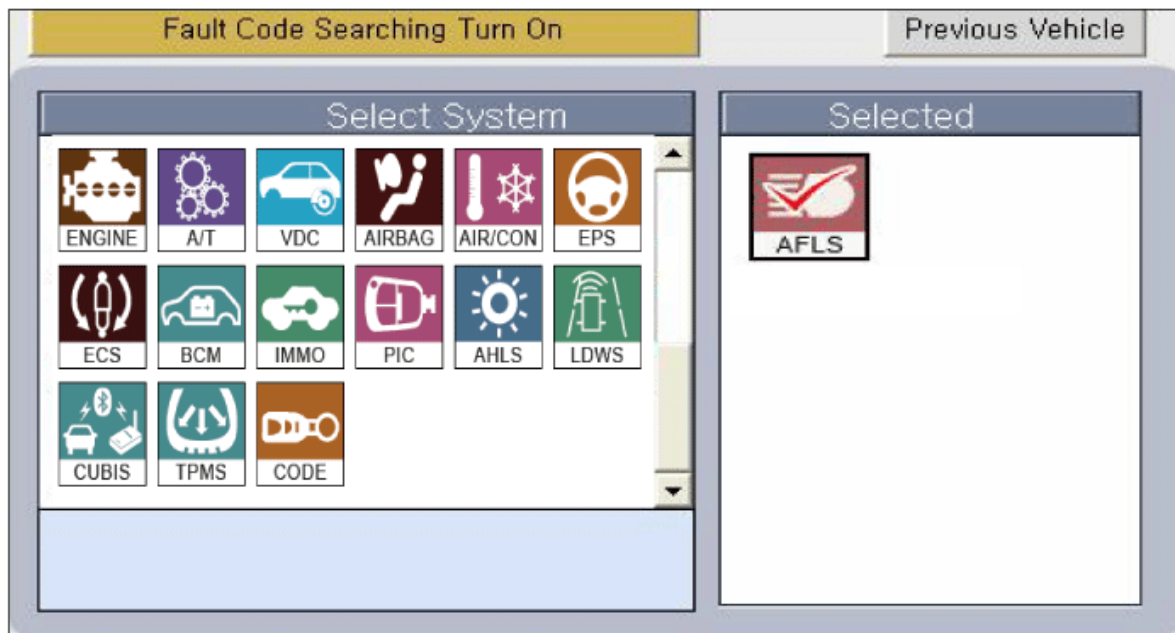

- Select "Parameter Download" menu for define a characteristic of vehicle.

ECU Information

➔ System Information

Data Treatment

➔ Parameter Down load

➔ Calibration

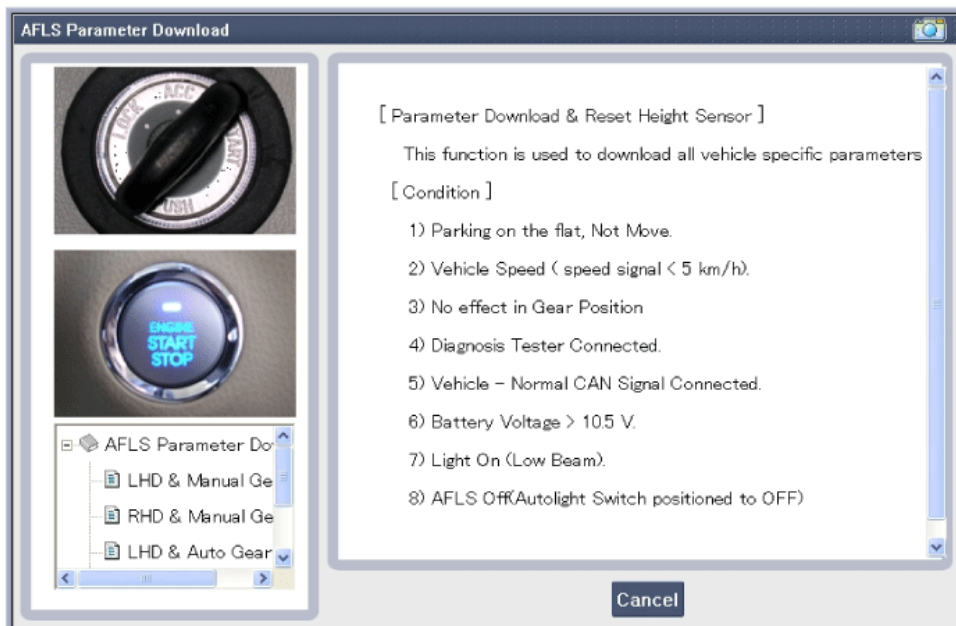

- Select the LHD/RHD and MT/AT option refer to the vehicle options.

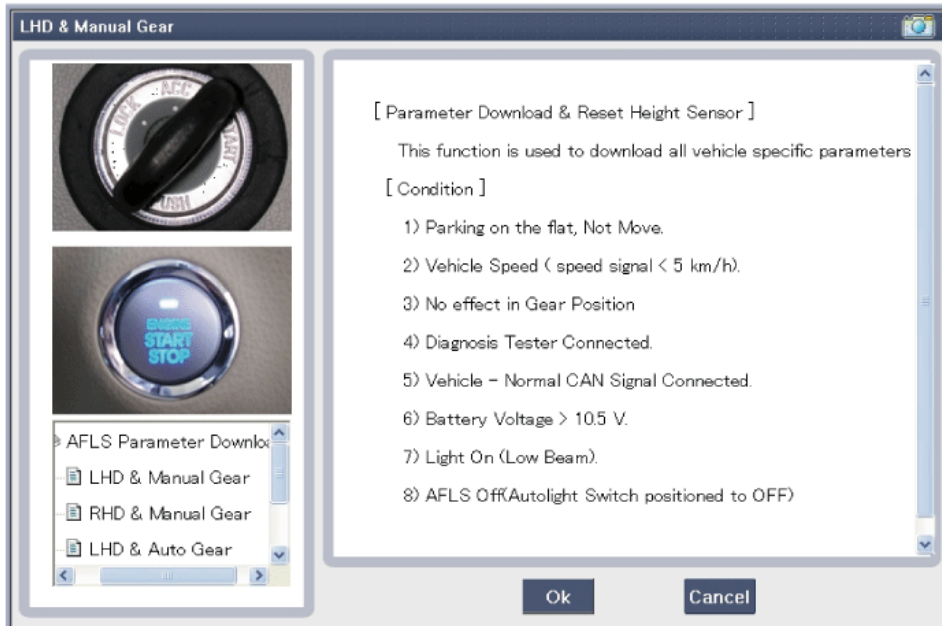

- When "Parameter Download" is done,display belows.

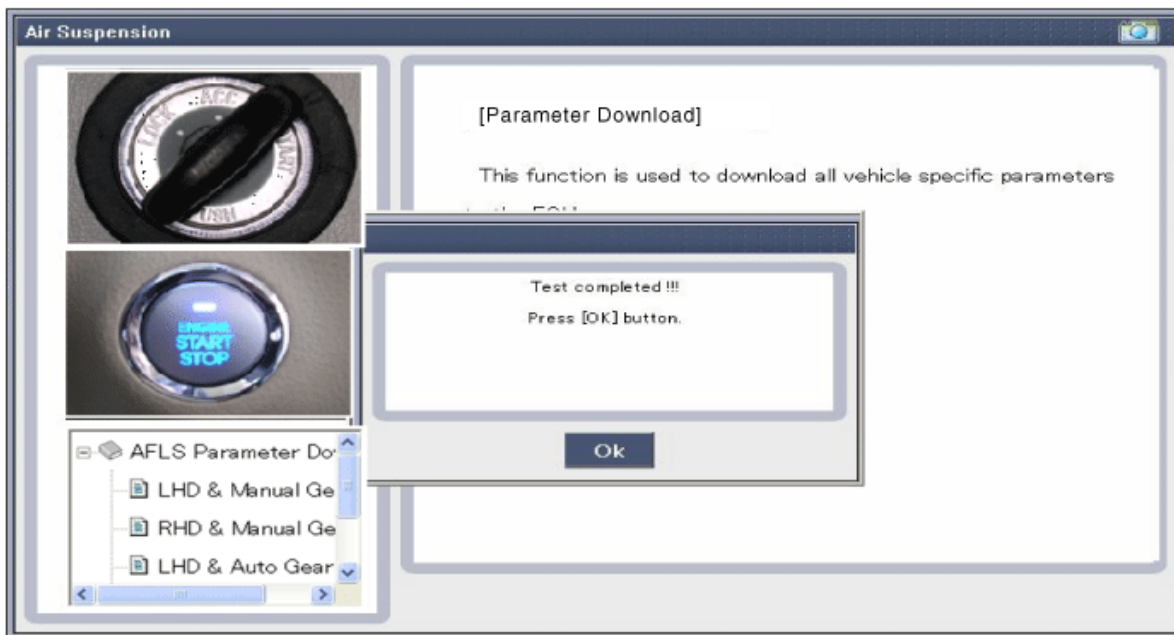

System Calibration

This menu is applied only if vehicle has a Steel suspension



- This menu is applied only if vehicle has a Steel suspension
- Select "AFS" menu after selecting a vehicle.
- Select "Sensor initializing-Non ECS" if vehicle has a Steel suspension

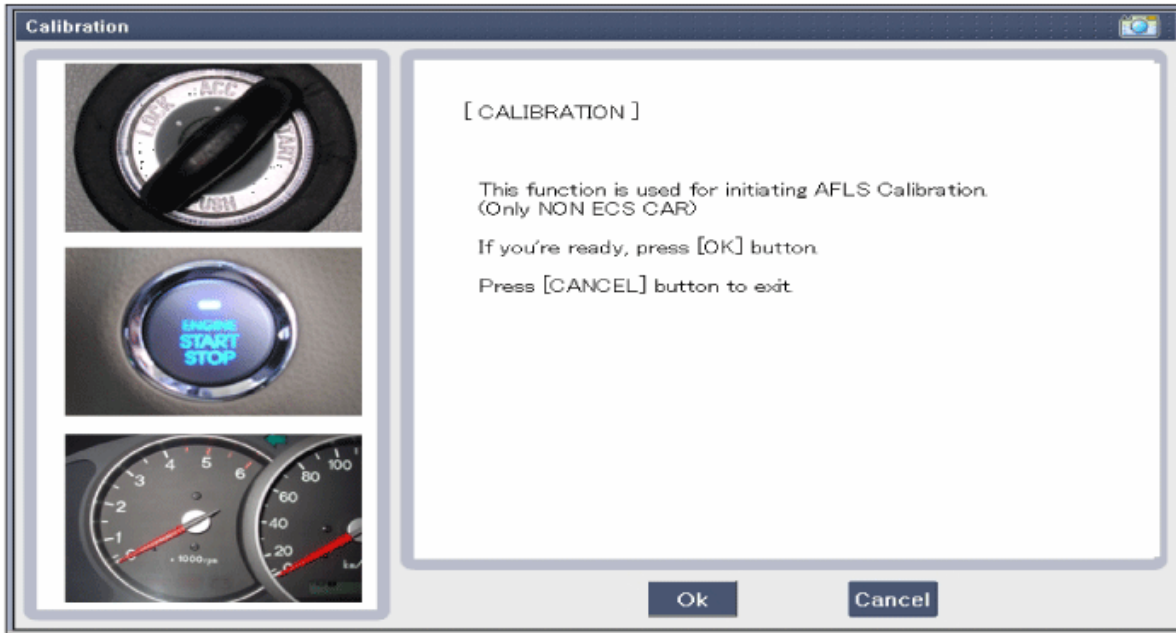

- When "System Calibration" is done, display belows.

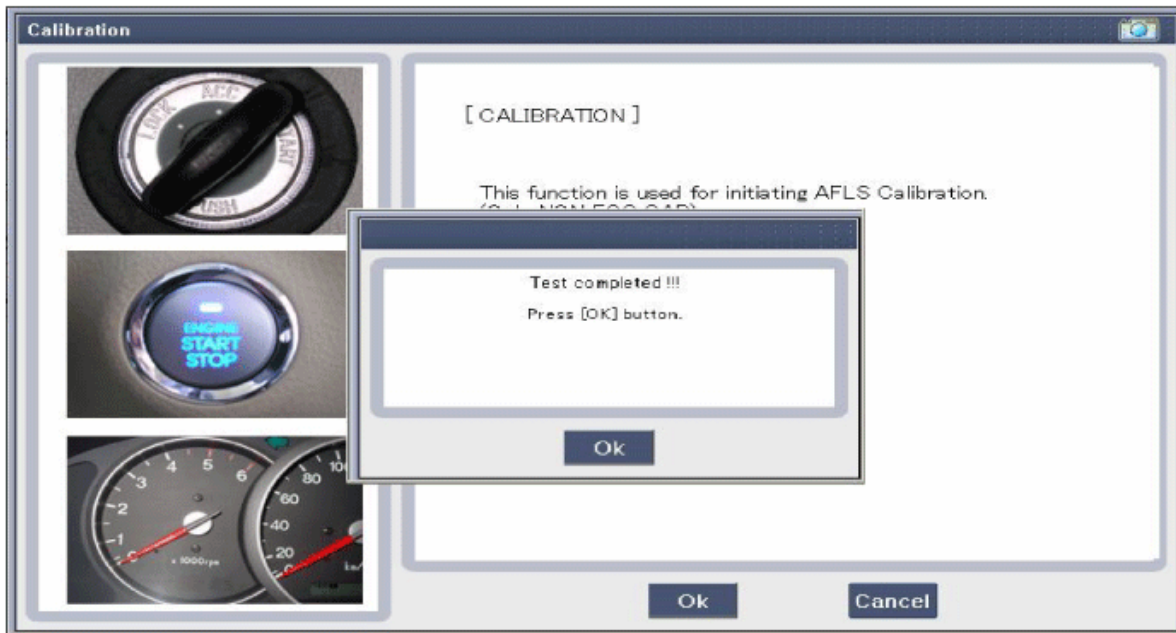

- When "System Calibration" is not done, display as belows.

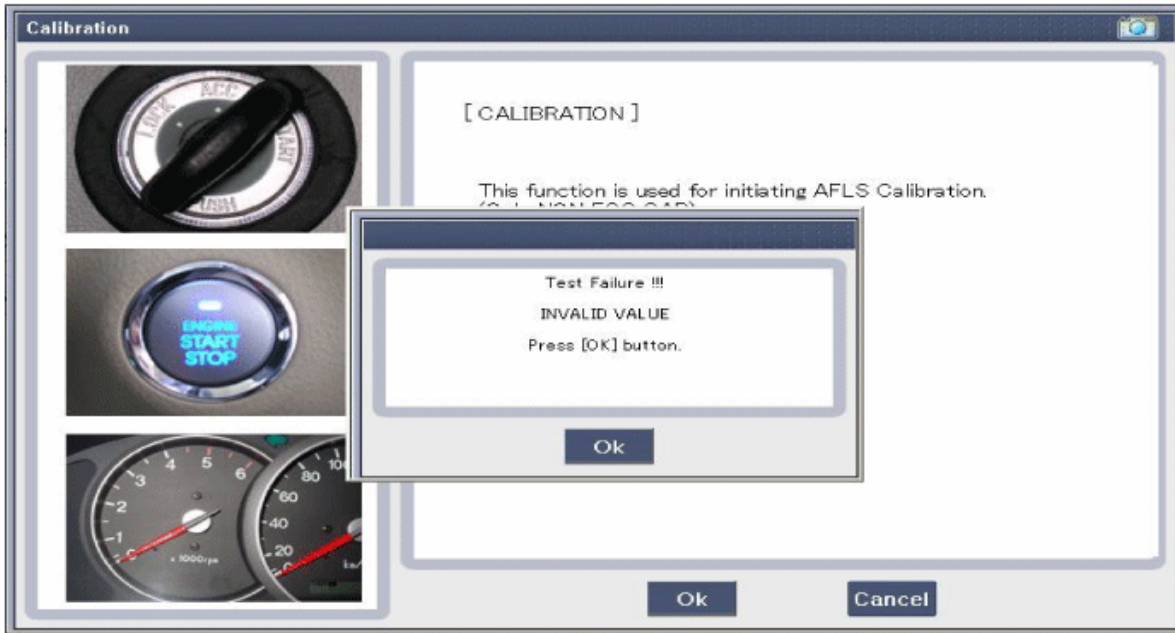

Actuator Test

- Select "Actuator Test"

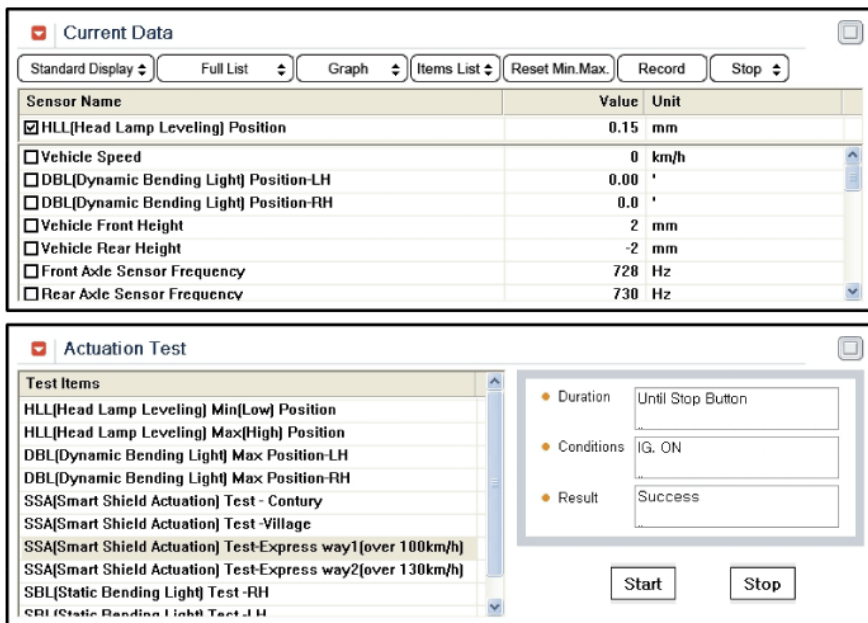

- Select DBL or HLL test by using "Start" button.

- In case select DBL or HLL ACTUATOR DRIVE TO MAX POS(swivelling) In case select "Start" button : drive to max position right direction (15°) In case select another item : back to initial position

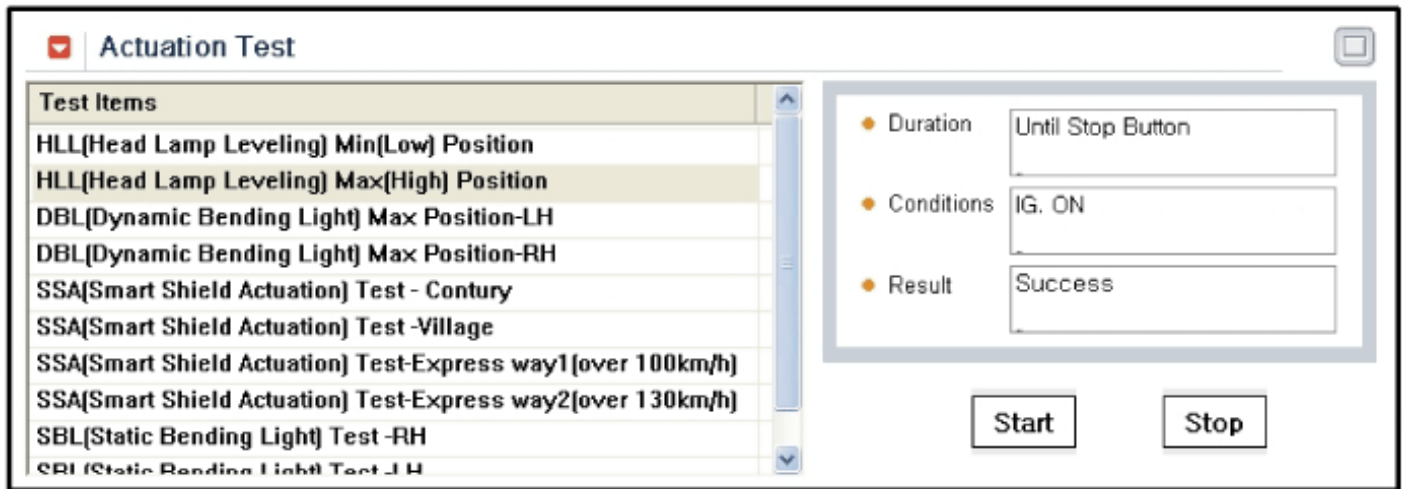

AFS Fail-safe Function

AFS Fail-safe Index

Part Content Fail-safe Reaction Tell-tale

ECU ECU Hardware (A/D Converter fail) 1) Levelling : staying in current POS 2) Swivelling : staying in current POS -

ECU Software (EEPROM/ROM fail) 1) Levelling : staying in current POS 2) Swivelling : staying in current POS
Control Unit not initialized Calibration not performed 1) Levelling : drive to error POS (H-15) 2) Swivelling : drive to error POS (0°)

Levelling module fault Right Short circuit 1) Right Levelling : staying in current POS 2) Left Levelling : normal operation 3) Swivelling : Normal operation -

Over temperature

LIN communication error 1) Right Levelling : staying in current POS(Before), drive to error POS 2) Left Levelling : normal operation 3) Swivelling : normal operation

Left Short circuit 1) Left Levelling : staying in current POS 2) Right Levelling : normal operation 3) Swivelling : Normal operation -

LIN communication error 1) Right Levelling : normal operation 2) Left Levelling : staying in current POS(Before), drive to error POS 3) Swivelling : normal operation

Swivelling module fault Right Short circuit 1) Right Swivelling : staying in current POS 2) Left Swivelling : drive to error POS 3) Right Levelling : drive to error POS 4) Left Levelling : Normal operation Tell-tale
Stall detected

LIN communication LIN fault Before 1) Swivelling : staying in current POS 2) Left Levelling : drive to error POS After 1) Swivelling : drive to error POS 2) Left Levelling : drive to error POS

DBL supply fault Before 1) Swivelling : staying in current POS 2) Left Levelling : drive to error POS

After 1) Right Swivelling : staying in current POS 2) Left Swivelling : drive to error POS 3) Left Levelling : drive to error POS

Left Short circuit 1) Left Swivelling : staying in current POS 2) Right Swivelling : drive to error POS 3)

Left Levelling : drive to error POS 4) Right Levelling : Normal operation Tell-tale

After 1) Left Swivelling : staying in current POS 2) Right Swivelling : drive to error POS 3) Left Levelling : drive to error POS

AXLE sensor Front & Rear external (5V) Sensor power supply fault (short to ground or to Bat) 1) Levelling : drive to error POS 2) Swivelling : Normal operation -

Front FREQ_LOWER , FREQ_UPPER 1) Levelling : drive to error POS 2) Swivelling : Normal operation

Signal line open circuit 1) Levelling : drive to error POS 2) Swivelling : Normal operation

Signal line short circuit

Front sensor out of range

Front sensor out of range FREQ_LOWER , FREQ_UPPER 1) Levelling : drive to error POS 2) Swivelling : Normal operation

Battery battery voltage too high 1) Levelling : staying in current POS (Before), drive to error POS 2)

Swivelling : staying in current POS (Before), drive to error POS -

battery voltage too low 1) Levelling : staying in current POS (Before), drive to error POS 2) Swivelling : staying in current POS (Before), drive to error POS

LIN physical fault Short circuit to battery or GND (physical fault) Before 1) Levelling : staying in current POS 2) Swivelling : staying in current POS Tell-tale

After 1) Levelling : drive to error POS 2) Swivelling : drive to error POS
 CAN communication fault Speed signal fault speed signal invalid 1) Levelling : Medium dynamic mode 2)
 Swivelling : drive to error POS -
 supplying ECU not available on CAN
 Steering angle signal fault Steering wheel sensor not O.K (signal invalid) 1) Levelling : normal operation 2)
 Swivelling : drive to error POS -
 Gearbox signal fault Reverse gear signal invalid 1) Levelling : normal operation 2) Swivelling : drive to
 error POS -
 Accelerator pedal signal fault Accelerator pedal signal invalid 1) Levelling : Medium dynamic mode 2) Swivelling :
 Normal operation -
 Engine state signal fault Engine state signal invalid 1) Levelling : Normal operation, no operation (Before)
 2) Swivelling : Normal operation, no operation (Before) -
 Yaw rate signal fault Yaw rate signal invalid 1) Levelling : Normal no operation(Before) 2) Swivelling :
 Reduced performance -
 Brake pedal signal fault Brake signal invalid 1) Levelling : Medium dynamic mode 2) Swivelling : Normal
 operation -
 CAN 'Bus off' fault ECU is isolated from the CAN network Air suspension 1) Swivelling : drive to error POS 2)
 Levelling : drive to error POS -
 Steel suspension 1) Swivelling : drive to error POS 2) Levelling : slow dynamic mode
 Lamp function Signal Fault Supplying ECU not available on CAN 1) Levelling : Normal operation 2) Swivelling :
 Normal operation -
 AFS Setting Procedure

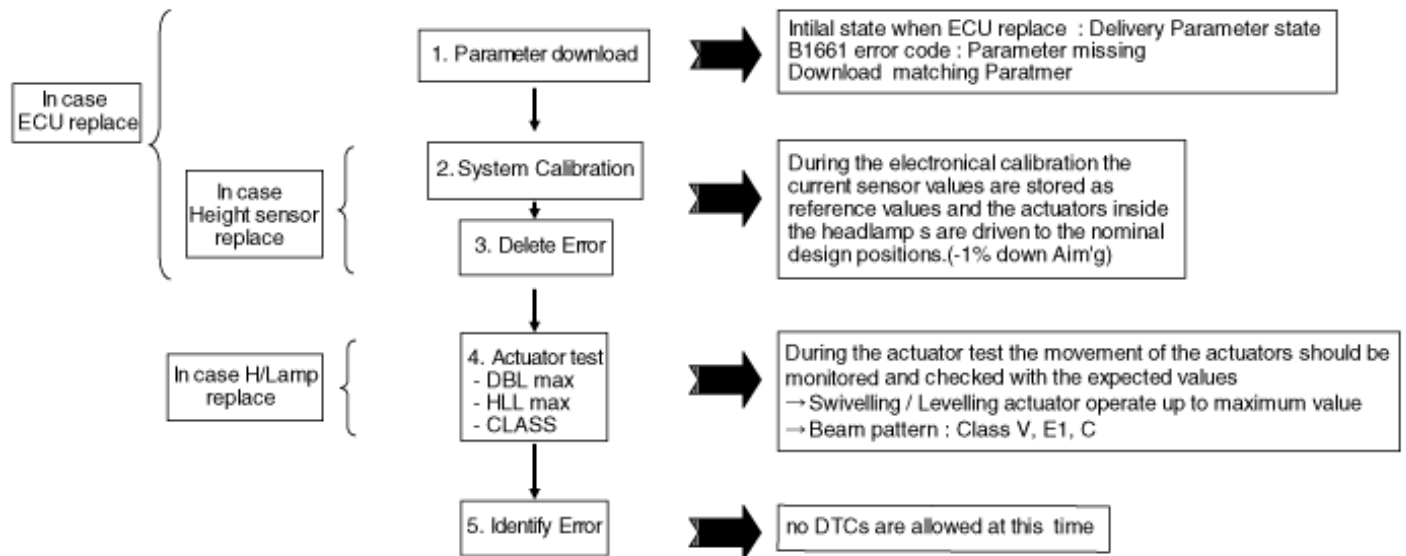

Vehicle Condition While AFS Setting

- Vehicle on an even surface
- No vehicle movement
- Gear position in P & N
- Ignition switched on & Engine RPM >500RPM
- Diagnostic equipment connected
- ALL ECUs on CAN mounted and activated
- Battery voltage > 10.5V (ECU supply to be ensured)
- Light switched
- AFS ON or OFF

Action In Case of Download Wrong Parameter

- Download Delivery Parameter
- Check up B1661(Parameter missing)
- Ignition OFF
- Ignition ON & Engine RPM > 500RPM
- Download matching Paratmer

Adaptive Front-Lighting System (AFS) Unit - Repair Procedures (Article 44684)

- Removal
- Disconnect the negative (-) battery terminal.
- Remove the glove box housing. (Refer to Body - "Glove Box Housing")
- Remove the AFS unit (A) after removing connector and nuts (2EA).



- Installation
- Install the AFS unit after connecting the connector.
- Install the glove box housing.
- Connect the negative (-) battery terminal.

Headlamps - Repair Procedures (Article 44649)

- Head Lamp Aiming Instructions

[Mechanical Aiming]

If there are any regulations pertinent to the aiming of head lamps in the area where the vehicle is to be used, adjust so as to meet those requirements.

NOTICE

- If there are any regulations pertinent to the aiming of head lamps in the area where the vehicle is to be used, adjust so as to meet those requirements.
- Inflate the tires to the specified pressure and remove any loads from the vehicle except the driver, spare tire, and tools.
- The vehicle should be placed on a flat floor.
- . Draw vertical lines (Vertical lines passing through respective head lamp centers) and a horizontal line (Horizontal line passing through center of head lamps) on the screen.
- With the head lamp and battery in normal condition, aim the head lamps so the brightest portion falls on the horizontal and vertical lines. A : Vertical (High beam / Low beam) Head lamp
- Head lamp

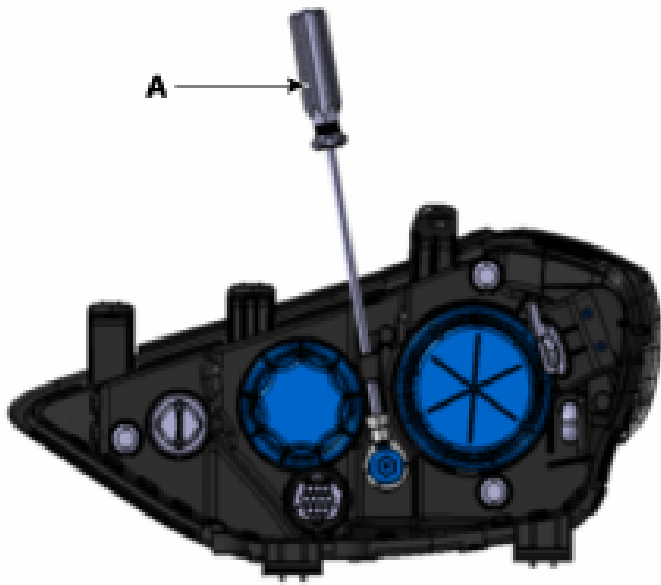

[General Type (Halogen, HID)]

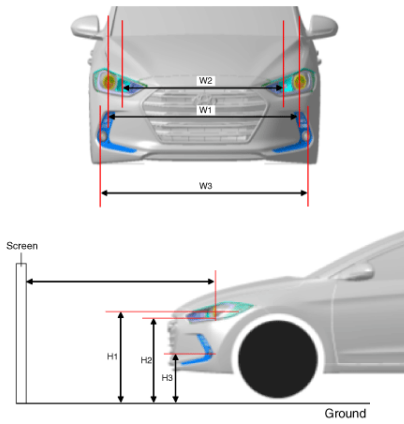

- H1 : Height between the head lamp bulb center and ground (Low beam)
- H2 : Height between the head lamp bulb center and ground (High beam)
- H3 : Height between the fog lamp bulb center and ground
- W1 : Distance between the two head lamp bulbs centers (Low beam)
- W2 : Distance between the two head lamp bulbs centers (High beam)
- W3 : Distance between the two fog lamp bulbs centers
- L : Distance between the head lamp bulb center and screen

Unit : In (mm)

Vehicle condition	H1	H2	H3	W1	W2	W3	L
Without driver	27.2 (693)	26.3 (670)	13.6 (347)	57.7 (1,466)	48.9 (1,242)	61.6 (1,565)	Refer to aiming condition
With driver	27.0 (686)	26.1 (663)	13.4 (340)				

[Sport Type (HID)]

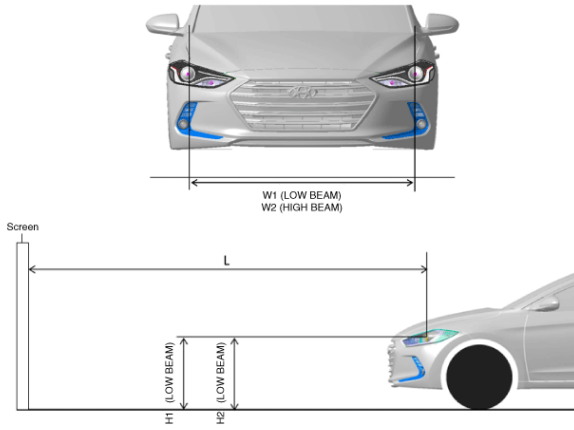

H1 : Height between the head lamp bulb center and ground (Low beam)
 H2 : Height between the head lamp bulb center and ground (High beam)
 W1 : Distance between the two head lamp bulbs centers (Low beam)
 W2 : Distance between the two head lamp bulbs centers (High beam)
 L : Distance between the head lamp bulb center and screen

Unit : In (mm)

Vehicle condition	H1	H2	W1	W2	L
Without driver	26.4 (672)		57.6 (1,464)		Refer to aiming condition
With driver	26.1 (665)				

- Head Lamp (Low beam) With the low beam turned on, adjust the cut-off line to be located as shown in the picture below. If head lamp leveling device is equipped, adjust the head lamp leveling device switch with 0 positions.
- With the low beam turned on, adjust the cut-off line to be located as shown in the picture below.
- If head lamp leveling device is equipped, adjust the head lamp leveling device switch with 0 positions.

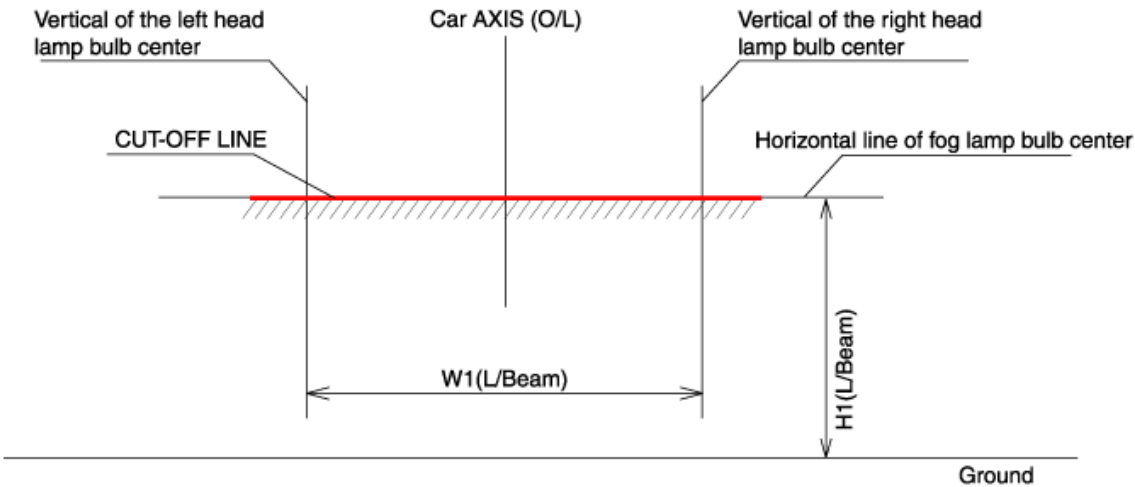

L : 25ft (7.6m)
 Unit : in. (mm)

- Turn the front fog lamp on without the driver aboard. The cut-off line should be projected in the allowable range (shaded region)

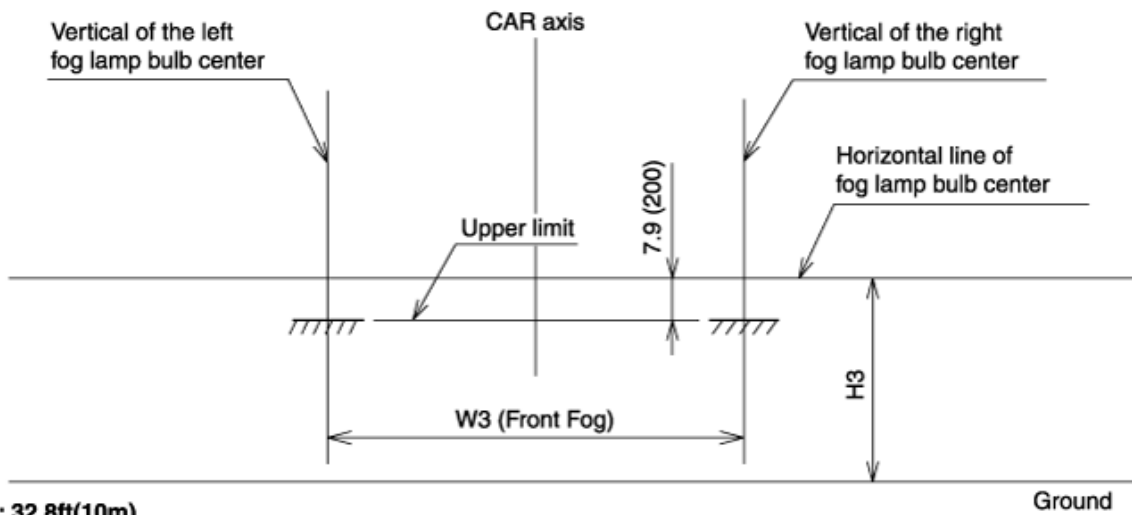

Head Lamp Fogging

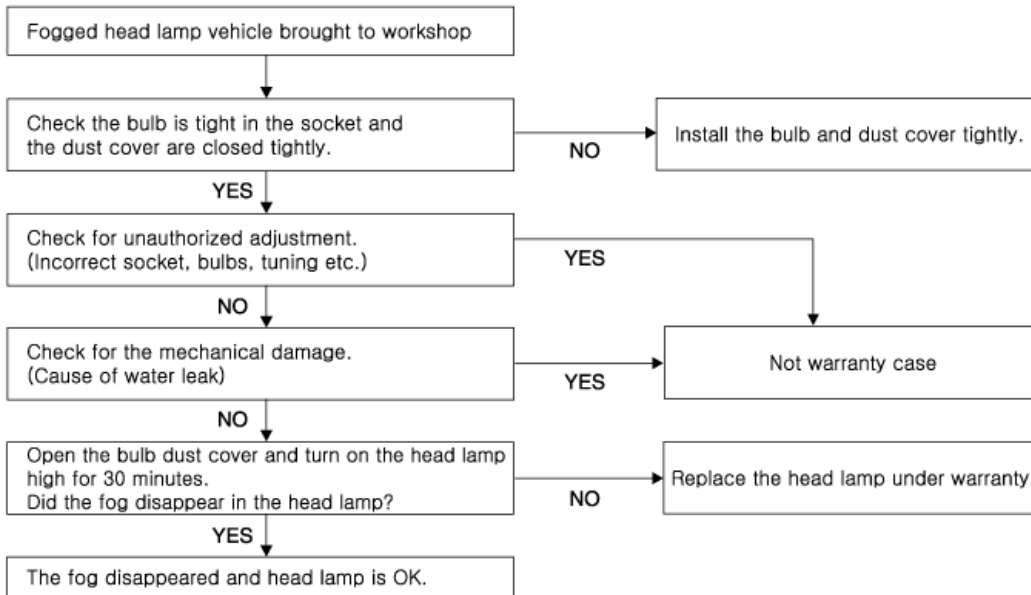

- Removal
- Disconnect the negative (-) battery terminal.
- Remove the front bumper cover. (Refer to Body - "Front Bumper Cover")
- Disconnect the head lamp connector (A).



- Remove the head lamp (B) mounting bolts. Take care that holding clip (A) is not to be damaged.

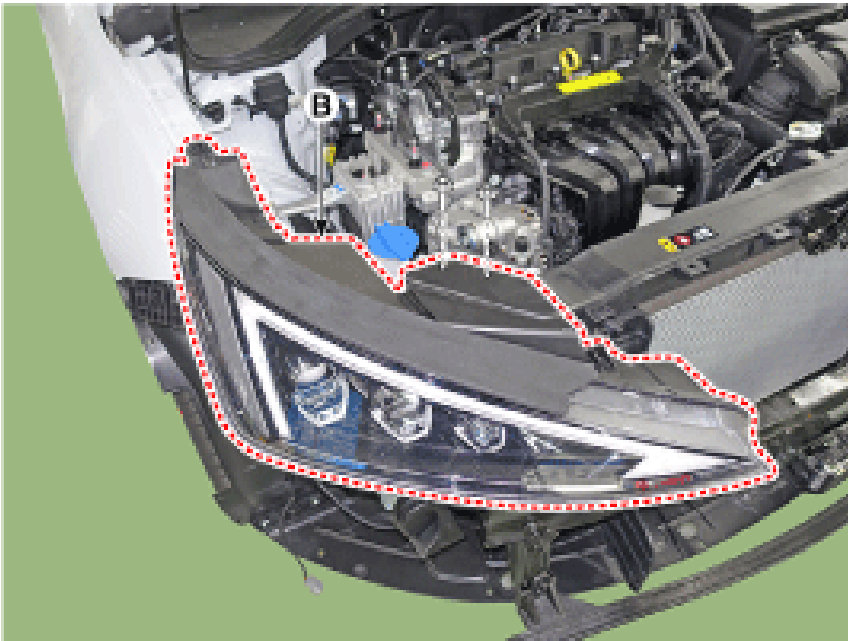

Take care that holding clip (A) is not to be damaged.
- Take care that holding clip (A) is not to be damaged.

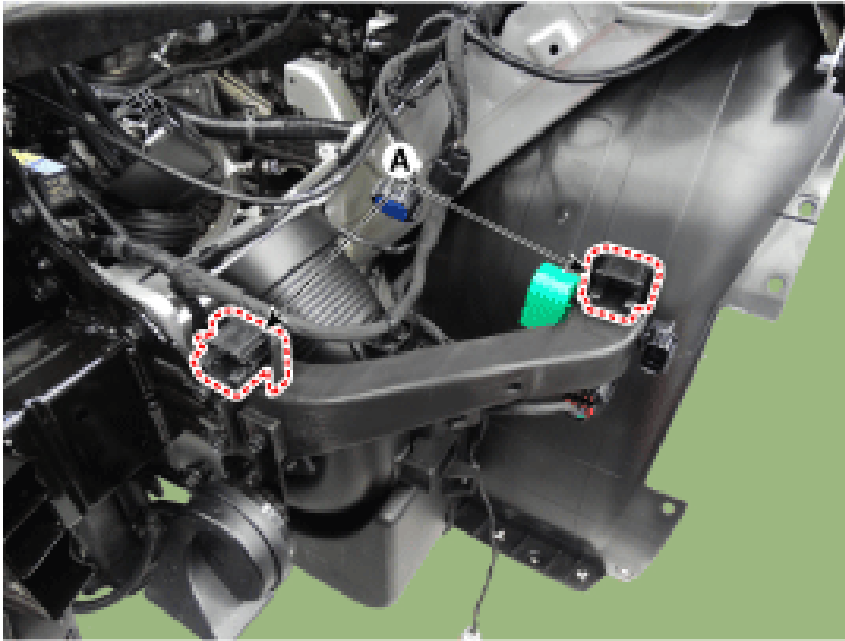

- Installation
- Install the head lamp assembly after connecting the connector.
- Install the front bumper cover.
- Connect the negative (-) battery terminal.
- Replacement
- [Side Marker Lamp]
- Remove the ignition key from the vehicle.
- Remove the bulb socket (B) and side marker bulb (A) from the lamp assembly.

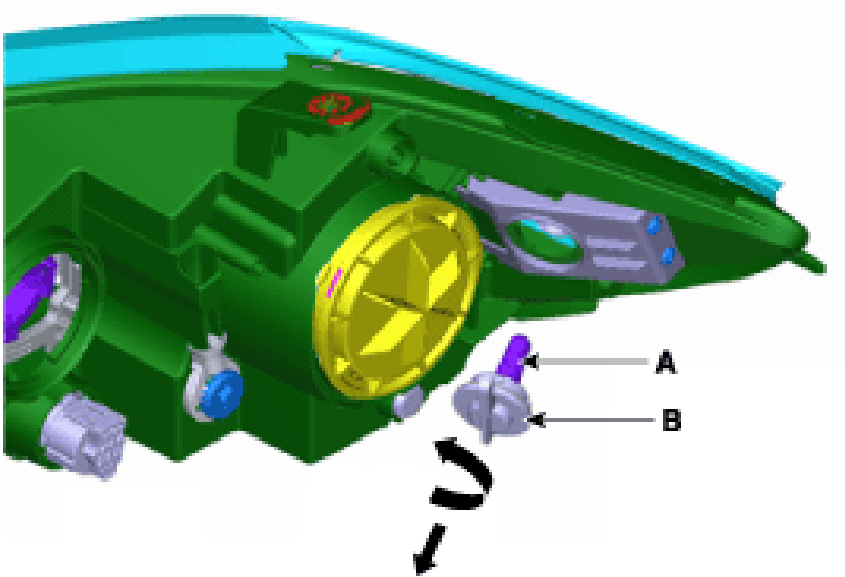

- [Daytime Running Light (DRL)]
- Turn the head lamp power off.
- Remove the bulb socket (B) and turn signal lamp bulb (A) from the lamp assembly.

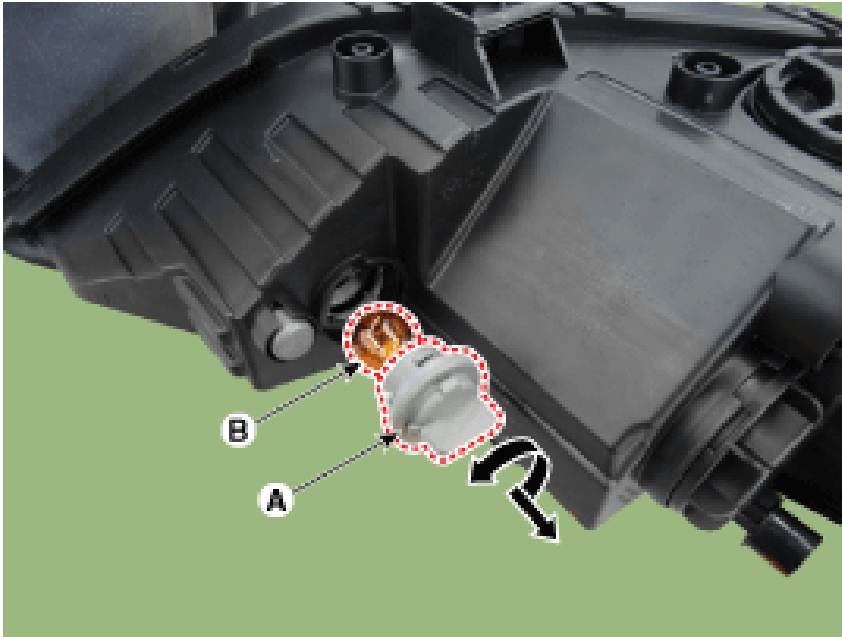

[Bulb (Low/High Beam)]

- Remove the bulb caps from the head lamp assembly after turning in the counter clock-wise direction.



[Moisture absorbent of the head lamp]

- After the testing of moisture, replace if necessary. Testing of moisture Start the engine , turn on the head lamp and open the dust cover. If there is moisture after 30 minutes, replace the moisture absorbent .
- Start the engine , turn on the head lamp and open the dust cover.
- If there is moisture after 30 minutes, replace the moisture absorbent .
- Turn and open the head lamp cover counterclockwise, as shown in the figure. Head lamp cover(Low/High beam)

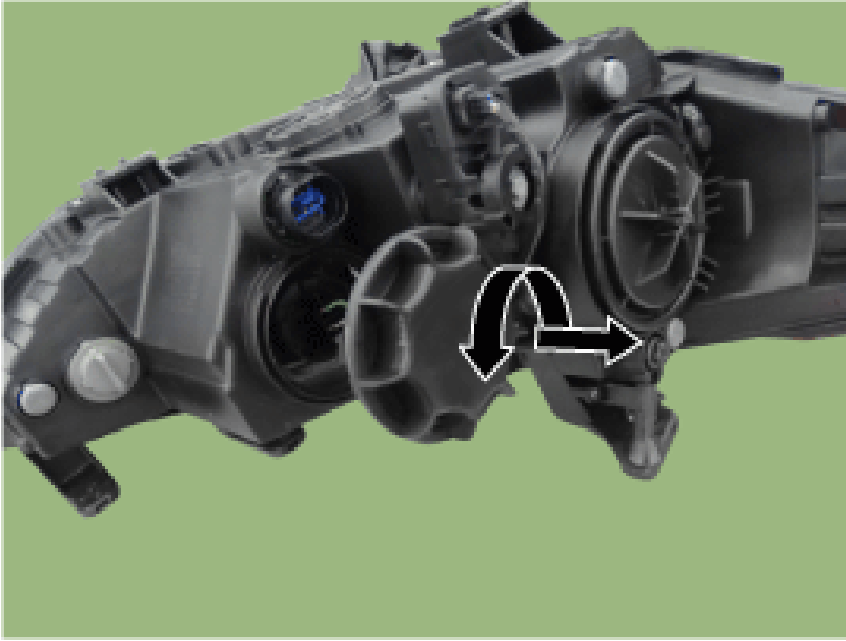

- Unfasten the 2 screws on the low beam and high beam head lamp cover bracket, separate the head lamp cover bracket (A), and then replace the moisture-absorbing agent (B). [High Beam] Grasp the moisture absorbent and form a round shape. Do not insert the moisture absorbent folded. Correct Incorrect Be careful to ensure that the moisture absorbent packaging is not damaged when fastening the screws.
[High Beam]



Grasp the moisture absorbent and form a round shape. Do not insert the moisture absorbent folded. Correct Incorrect Be careful to ensure that the moisture absorbent packaging is not damaged when fastening the screws.



- Grasp the moisture absorbent and form a round shape.

- Do not insert the moisture absorbent folded. Correct Incorrect
Correct Incorrect





- Be careful to ensure that the moisture absorbent packaging is not damaged when fastening the screws.

Adaptive Front-Lighting System (AFS) - Specifications (Article 44677)

- Specifications

Content Value

AFS Nominal Voltage DC 13.5V

Max Voltage DC 18.5V

Rated Voltage DC 10-16V

Operating Temperature -40°C to +85°C

Operating Current MAX. 200 mA

Auto Lighting Control System - Specifications (Article 44657)

- Specifications

Items Specifications

Rated voltage 5V

Load Max. 1mA (Relay load)

Illuminations (LUX) 50 1.42 ± 0.31V

100 2.63 ± 0.58V

150 3.84 ± 0.84V

All New Technical Service Bulletins (itype_432)

Tsbs

- INFORMATION FOR LAMP CONDENSATION (25-BD-012H, 2025/11/05)

All Technical Service Bulletins (itype_100)

Tsbs

- HEADLAMP REPLACEMENT AND AIMING ADJUSTMENT (20-BE-004H, 2020/03/25)
- HEAD LAMP HIGH BEAM REPAIR (SERVICE CAMPAIGN T5G) (23-01-094H, 2023/12/14)
- INFORMATION FOR LAMP CONDENSATION (25-BD-012H, 2025/11/05)
- ANTIGLARE HEADLIGHT PATTERN (18-BE-003-1, 2018/12/13)
- HEADLAMP REPLACEMENT AND AIMING ADJUSTMENT (SERVICE CAMPAIGN T3J) (20-01-011H, 2020/03/05)

Auto Lights - Service Tips (Article 42593)

Auto Lights	Service Tips (1)																						
<p>Circuit Description</p> <p>To operate the Auto lights, the ignition switch must be in the ON position or higher. Lights switch Auto mode automatically controls the head lamp and tail lamp depends on driving condition (rain, snow, night, tunnel) using the auto lights & photo sensor which detects brightness of surrounding the vehicle.</p> <p>■ Caution</p> <ol style="list-style-type: none">1. Do not place anything over the sensor.2. In fog, rain or cloudy weather, use manual mode.3. Auto lights ON/OFF time will changed depend on surrounding environment (weather, climate).4. Use this mode for sunrise and sunset. Control the lamp ON/OFF switch manually.5. If the glass of the vehicle is filmed or tinted, it may cause the sensor malfunction. <p>■ Dimmer/ Passing Switch : LOW</p> <p>In the light switch AUTO position, when the dimmer/passing switch is placed in LOW, BCM received signal and transmit it to IPS control module through the CAN communication. IPS control module control ARISU (4CH) to turn on the head lamp (LOW). Result of control and diagnosis is send to BCM through the CAN communication.</p> <p>■ Dimmer/ Passing Switch : HIGH</p> <p>In the light switch AUTO position, when the dimmer/passing switch is placed in HIGH, BCM received signal and transmit it to IPS control module and cluster instrument through the CAN communication.</p> <p>MICOM in cluster instrument turn on the high beam indicator, and IPS control module control ARISU (4CH) to turn on the head lamp (HIGH). Result of control and diagnosis is send to BCM through the CAN communication.</p>	<p>■ Multifunction Switch Inspection</p> <p>When each switch is pressed, check the electricity flow between multi-function switch connector and grounding, and if the electricity does not match the specification, replace the switch.</p> <table border="1"><thead><tr><th>Switch</th><th>Switch position</th><th>Switch position</th><th>Resistance (Ω , ± 3.5%)</th></tr></thead><tbody><tr><td rowspan="3">Dimmer & Passing switch</td><td>OFF</td><td rowspan="3">9-13</td><td>—</td></tr><tr><td>PASSING</td><td>910</td></tr><tr><td>DIMMER</td><td>2910</td></tr><tr><td rowspan="4">Light switch</td><td>OFF</td><td rowspan="4">9-14</td><td>680</td></tr><tr><td>AUTO</td><td>—</td></tr><tr><td>TAIL LAMP</td><td>1680</td></tr><tr><td>HLAMP (Low)</td><td>5580</td></tr></tbody></table> <p>0.3G 0.22N 0.22G 0.22G 0.3</p>	Switch	Switch position	Switch position	Resistance (Ω , ± 3.5%)	Dimmer & Passing switch	OFF	9-13	—	PASSING	910	DIMMER	2910	Light switch	OFF	9-14	680	AUTO	—	TAIL LAMP	1680	HLAMP (Low)	5580
Switch	Switch position	Switch position	Resistance (Ω , ± 3.5%)																				
Dimmer & Passing switch	OFF	9-13	—																				
	PASSING		910																				
	DIMMER		2910																				
Light switch	OFF	9-14	680																				
	AUTO		—																				
	TAIL LAMP		1680																				
	HLAMP (Low)		5580																				

Head Lamps - Service Tips (Article 42494)

Head Lamps	Service Tips (1)																						
<p>Circuit Description</p> <p>To operate the head lamp, the ignition switch must be in the IG2 position or higher. Rotate the light switch of the multifunction switch to the HEAD position and determine LOW/HIGH of the dimmer/passing switch.</p> <p>Generally, the dimmer/passing switch is placed in the LOW position.</p> <p>■ Dimmer/ Passing Switch : LOW</p> <p>In the light switch HEAD position, when the dimmer/passing switch is placed in LOW, BCM received signal and transmit it to IPS control module through the CAN communication. IPS control module control ARISU (4CH) to turn on the head lamp (LOW). Result of control and diagnosis is send to BCM through the CAN communication.</p> <p>■ Dimmer/ Passing Switch : HIGH</p> <p>In the light switch HEAD position, when the dimmer/passing switch is placed in HIGH, BCM received signal and transmit it to IPS control module and cluster instrument through the CAN communication.</p> <p>MICOM in cluster instrument turn on the high beam indicator, and IPS control module control ARISU (4CH) to turn on the head lamp (HIGH). Result of control and diagnosis is send to BCM through the CAN communication.</p> <p>■ Dimmer/ Passing Switch : PASS</p> <p>It can be operated regardless of the light switch HEAD position. Pull the dimmer/passing switch toward the driver 2-3 times to warn other vehicles and to turn on the high beam indicator light on the instrument cluster and head lamp.</p> <p>■ Control Function - CAN FAIL</p> <p>If CAN is failed and ignition switch is ON, Smart junction block turn ON the head lamp (LOW) by force for driver safety.</p>	<p>■ Multifunction Switch Inspection</p> <p>When each switch is pressed, check the electricity flow between multi-function switch connector and grounding, and if the electricity does not match the specification, replace the switch.</p> <table border="1"><thead><tr><th>Switch</th><th>Switch position</th><th>Switch position</th><th>Resistance (Ω , ± 3.5%)</th></tr></thead><tbody><tr><td rowspan="3">Dimmer & Passing switch</td><td>OFF</td><td rowspan="3">9-13</td><td>—</td></tr><tr><td>PASSING</td><td>910</td></tr><tr><td>DIMMER</td><td>2910</td></tr><tr><td rowspan="4">Light switch</td><td>OFF</td><td rowspan="4">9-14</td><td>680</td></tr><tr><td>AUTO</td><td>—</td></tr><tr><td>TAIL LAMP</td><td>1680</td></tr><tr><td>HLAMP (Low)</td><td>5580</td></tr></tbody></table> <p>0.3G 0.22N 0.22G 0.22G 0.3</p>	Switch	Switch position	Switch position	Resistance (Ω , ± 3.5%)	Dimmer & Passing switch	OFF	9-13	—	PASSING	910	DIMMER	2910	Light switch	OFF	9-14	680	AUTO	—	TAIL LAMP	1680	HLAMP (Low)	5580
Switch	Switch position	Switch position	Resistance (Ω , ± 3.5%)																				
Dimmer & Passing switch	OFF	9-13	—																				
	PASSING		910																				
	DIMMER		2910																				
Light switch	OFF	9-14	680																				
	AUTO		—																				
	TAIL LAMP		1680																				
	HLAMP (Low)		5580																				

Erratic Operation (itype_132)

Tsbs

- HEADLAMP REPLACEMENT AND AIMING ADJUSTMENT (SERVICE CAMPAIGN T3J) (20-01-011H, 2020/03/05)

Miscellaneous Information (itype_111)

Tsbs

- ANTIGLARE HEADLIGHT PATTERN (18-BE-003-1, 2018/12/13)

OEM Policies and Procedures (itype_120)

Tsbs

- HEADLAMP REPLACEMENT AND AIMING ADJUSTMENT (20-BE-004H, 2020/03/25)

Service Campaigns (itype_108)

Tsbs

- HEAD LAMP HIGH BEAM REPAIR (SERVICE CAMPAIGN T5G) (23-01-094H, 2023/12/14)
- HEADLAMP REPLACEMENT AND AIMING ADJUSTMENT (SERVICE CAMPAIGN T3J) (20-01-011H, 2020/03/05)