

Component Procedures: Timing Chain

Table of Contents

1. Parts and Labor (itype_189)
2. Timing Chain - Components and Components Location (Article 45336)
3. Timing Chain - Repair Procedures (Article 45337)

Component Procedures: Timing Chain

Parts and Labor (itype_189)

Parts

| Qualifier | Part # | Name | Price | Note |
|-------------------------------|------------|-------------------|--------|------|
| Camshaft & Timing > Timing C? | 243212E010 | 14 - Timing Chain | 145.82 | |

Labor

| Operation | Qualifier Path | Skill | Std Hrs | Wty Hrs |
|------------------|--|-------|---------|---------|
| Remove & Replace | Camshaft & Timing > Timing Chain, R&R | B | 6.8 | 0.0 |
| Remove & Replace | Camshaft & Timing > Timing Chain, R&R > NOTE ? | | 0.1 | |
| Remove & Replace | Camshaft & Timing > Timing Chain, R&R > NOTE ? | | 0.1 | |

Timing Chain - Components and Components Location (Article 45336)

- Components

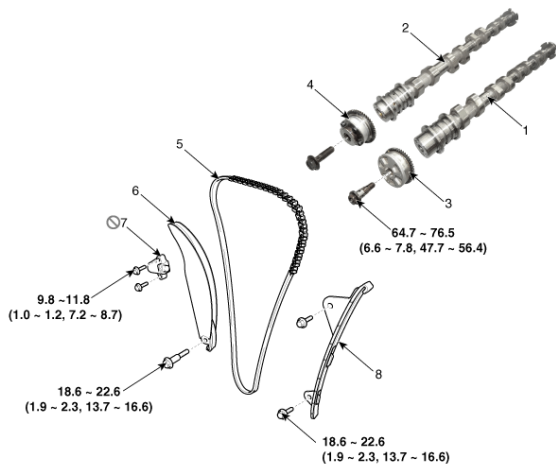

Tightening torque : N.m (kgf.m, lb-ft)

1. Intake camshaft 2. Exhaust camshaft 3. Intake CVVT assembly 4. Exhaust CVVT assembly 5. Timing chain 6. Timing chain tensioner arm 7. Timing chain tensioner 8. Timing chain guide

Timing Chain - Repair Procedures (Article 45337)

- Removal

- Remove the cylinder head cover . (Refer to Cylinder Head Assembly - "Cylinder Head Cover")
- Set No.1 cylinder to TDC (Top dead center) on compression stroke. Turn the crankshaft pulley and align its groove with the timing mark of the timing chain cover . Check that the TDC marks of the intake and exhaust CVVT sprockets are in straight line on the cylinder head surface as shown in the illustration. If not, turn the crankshaft by one revolution (360°) more. Do not turn the crankshaft pulley counterclockwise.
- Turn the crankshaft pulley and align its groove with the timing mark of the timing chain cover .

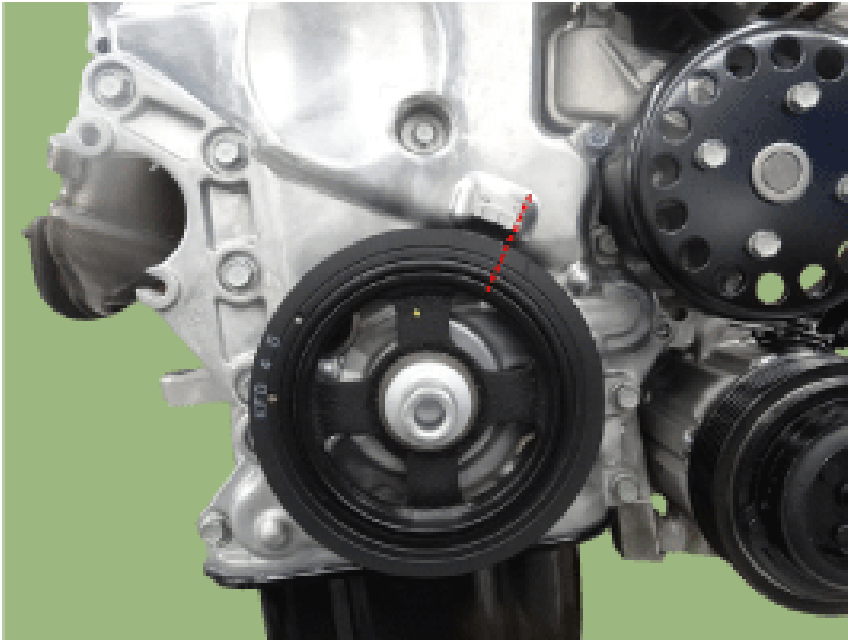

- Check that the TDC marks of the intake and exhaust CVVT sprockets are in straight line on the cylinder head surface as shown in the illustration. If not, turn the crankshaft by one revolution (360°) more. Do not turn the crankshaft pulley counterclockwise.

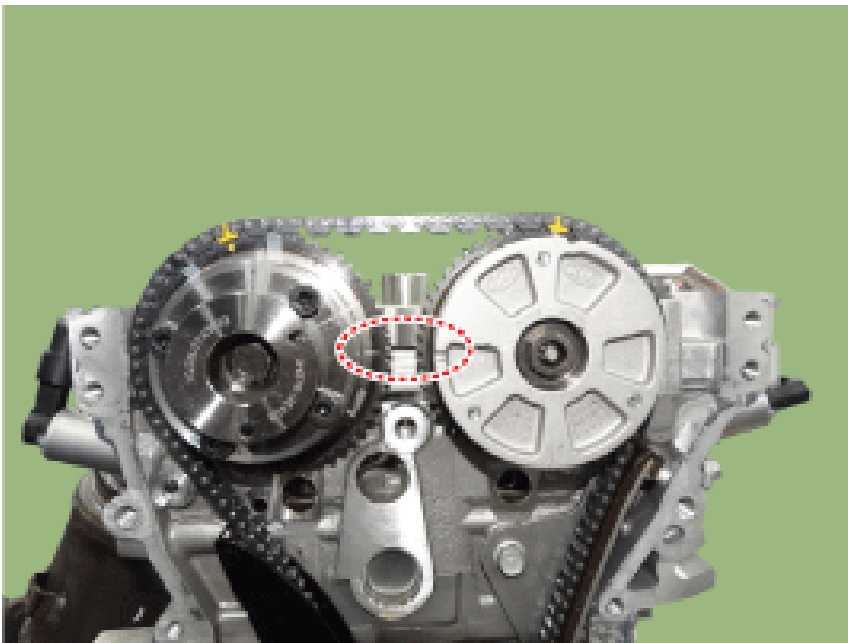

Do not turn the crankshaft pulley counterclockwise.

NOTICE

- Do not turn the crankshaft pulley counterclockwise.
- Remove the timing chain cover. (Refer to Timing System - "Timing Chain Cover")
- Remove the timing chain tensioner (A). Do not reuse the detached tensioner.

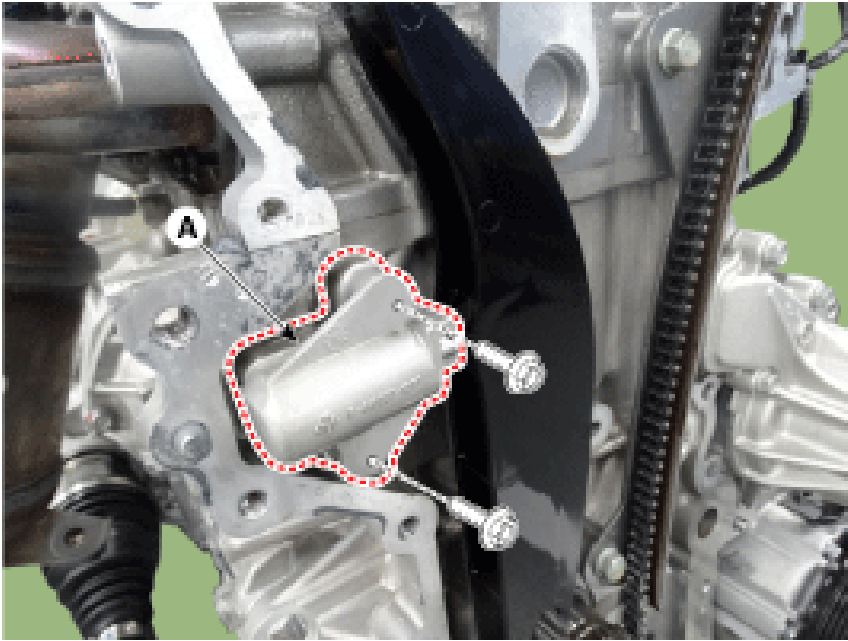

- Do not reuse the detached tensioner.
- Do not reuse the detached tensioner.
 - Remove the timing chain tensioner arm (A).

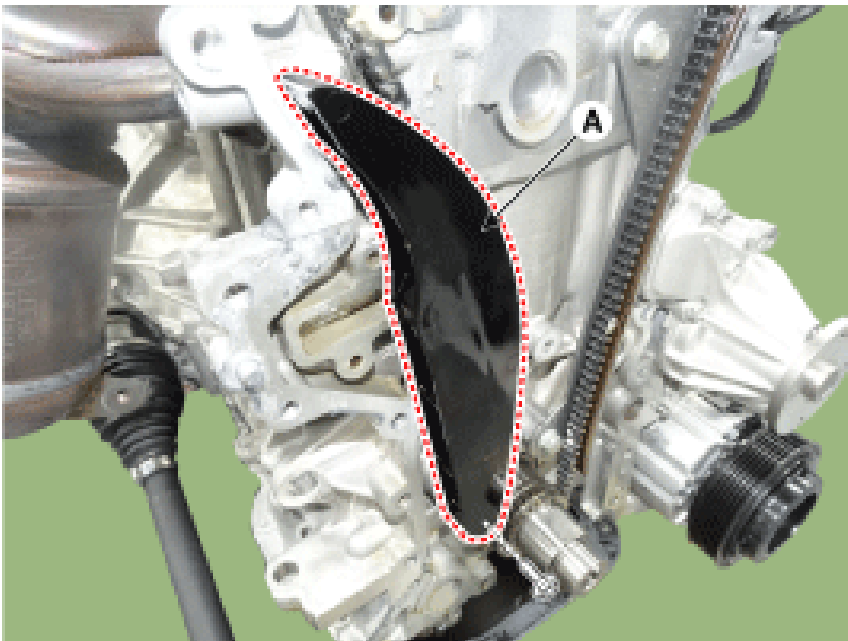

- Remove the timing chain (A).

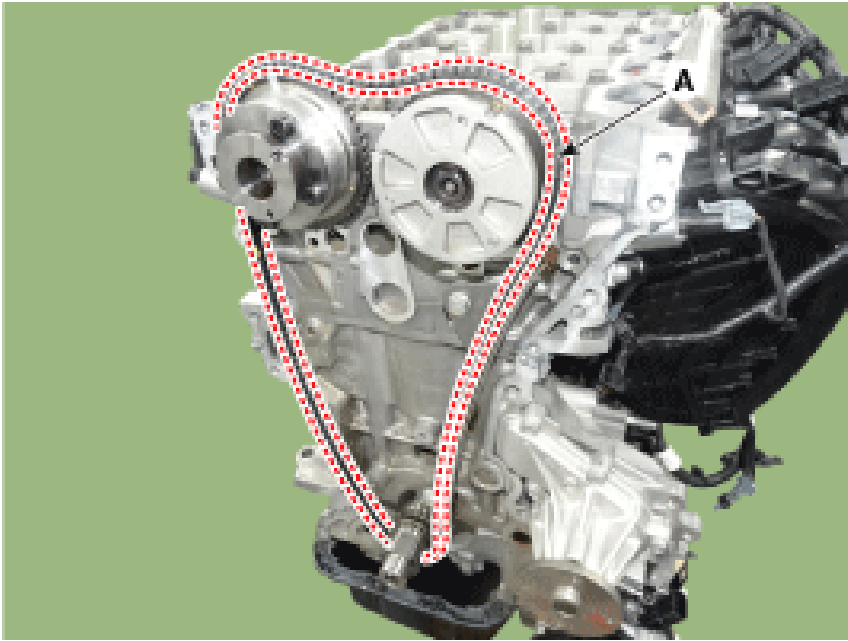

- Remove the timing chain guide (A).

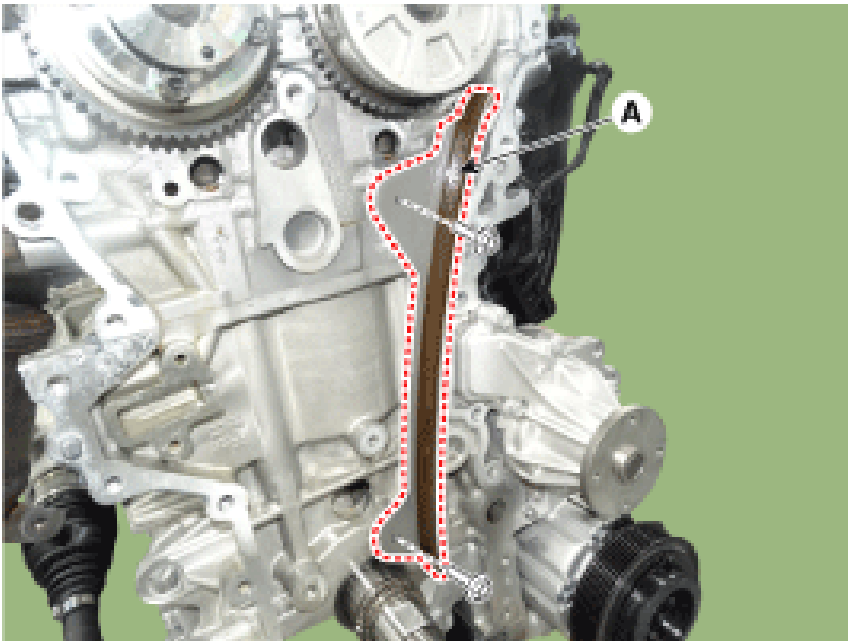

- Inspection
Sprockets, Chain Tensioner, Chain Guide, Chain Tensioner Arm
- Check the CVVT sprocket and crankshaft sprocket for abnormal wear, cracks, or damage. Replace if necessary.
- Inspect the tensioner arm and chain guide for abnormal wear, cracks, or damage. Replace if necessary.
- Installation
- The TDC marks of the intake and exhaust CVVT sprockets are slightly turned from the TDC position as shown when the timing chain is removed.

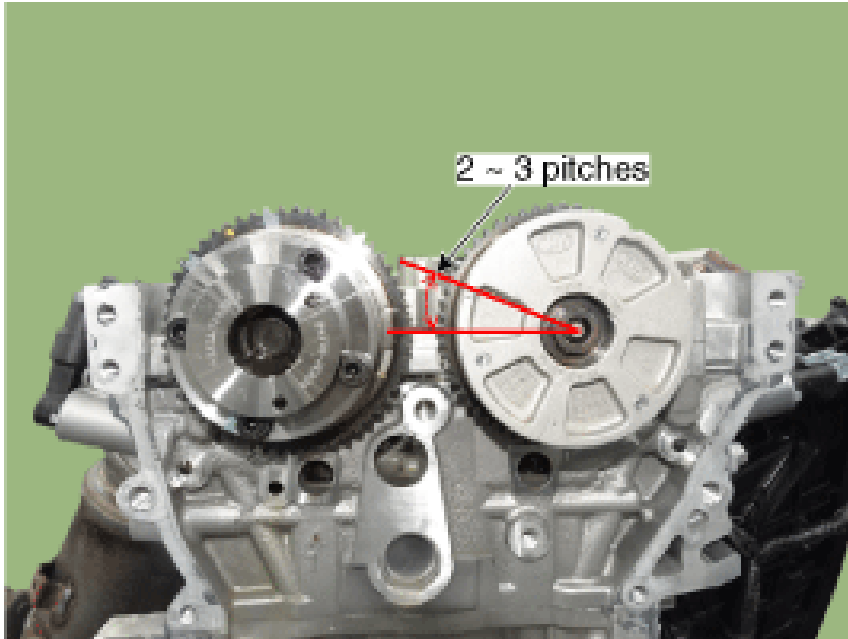

- Turn the crankshaft clockwise (about 2-3 pitches) from the TDC position (the dowel pin (A) of crankshaft is about 3° with the engine vertical line) as rotation of the intake CVVT sprocket from the TDC position.

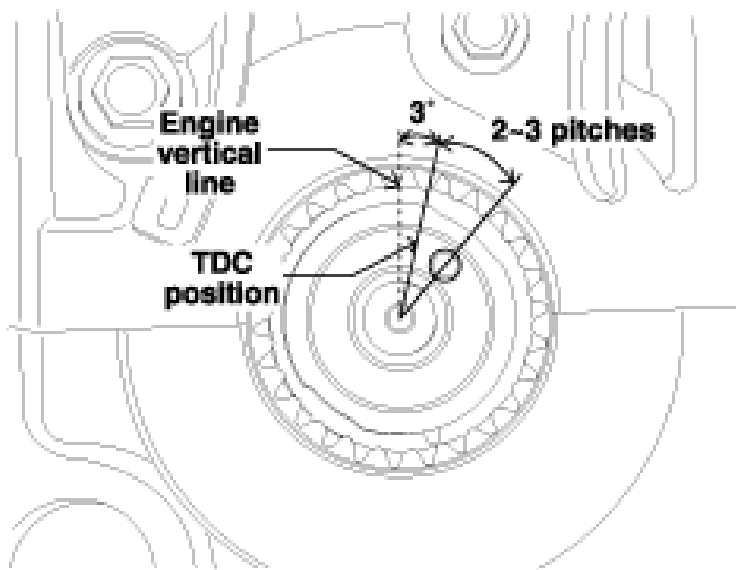

- Install the timing chain guide (A). Tightening torque : 18.6 - 22.6 N.m (1.9 - 2.3 kgf.m, 13.7 - 16.6 lb-ft)
- Install the timing chain tensioner arm (A). Tightening torque : 18.6 - 22.6 N.m (1.9 - 2.3 kgf.m, 13.7 - 16.6 lb-ft)
- Install the timing chain. Crankshaft sprocket → Timing chain guide → Intake CVVT sprocket → Exhaust CVVT sprocket. Install the timing chain with no slack between the crankshaft sprocket and the intake CVVT sprocket. The timing marks of each sprocket should be matched with timing marks (color link) of timing chain when installing the timing chain. Install the timing chain on the exhaust CVVT sprocket with no slack while turning the CVVT assembly clockwise. The timing mark of the exhaust CVVT sprocket should be matched with timing mark (color link) of timing chain when installing the timing chain. Press down the timing chain links on the exhaust CVVT sprocket to prevent the sprocket from spinning.
- Install the timing chain with no slack between the crankshaft sprocket and the intake CVVT sprocket. The timing marks of each sprocket should be matched with timing marks (color link) of timing chain when installing the timing chain.

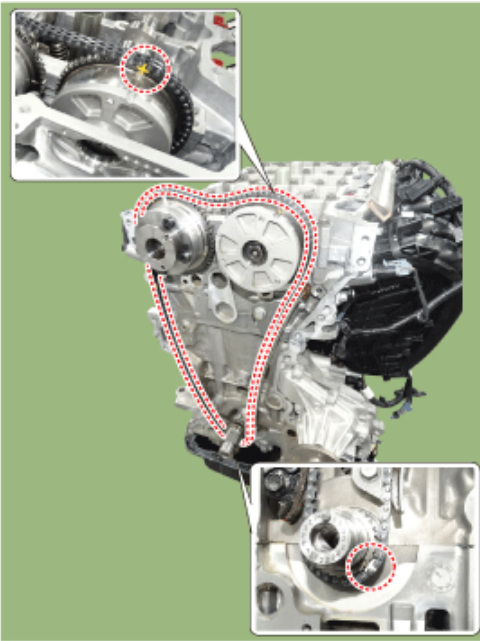

The timing marks of each sprocket should be matched with timing marks (color link) of timing chain when installing the timing chain.

- The timing marks of each sprocket should be matched with timing marks (color link) of timing chain when installing the timing chain.
- Install the timing chain on the exhaust CVVT sprocket with no slack while turning the CVVT assembly clockwise. The timing mark of the exhaust CVVT sprocket should be matched with timing mark (color link) of timing chain when installing the timing chain. Press down the timing chain links on the exhaust CVVT sprocket to prevent the sprocket from spinning.

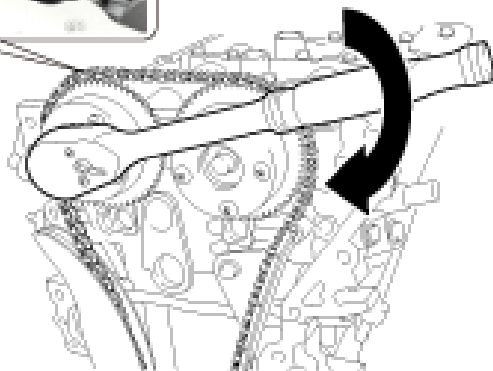

The timing mark of the exhaust CVVT sprocket should be matched with timing mark (color link) of timing chain when installing the timing chain. Press down the timing chain links on the exhaust CVVT sprocket to prevent the sprocket from spinning.

- The timing mark of the exhaust CVVT sprocket should be matched with timing mark (color link) of timing chain when installing the timing chain.
- Press down the timing chain links on the exhaust CVVT sprocket to prevent the sprocket from spinning.
- Install the timing chain auto tensioner (A) and remove the stopper pin (B). Tightening torque : 9.8 - 11.8 N.m (1.0 - 1.2 kgf.m, 7.2 - 8.7 lb-ft) When reinstall the tensioner, check the ratchet function of the tensioner after removing the fixing pin by retracting the tensioner arm (A) maximally as shown below. When maximally retracted, there should be no interference between the tensioner arm (A) and tensioner housing (B).

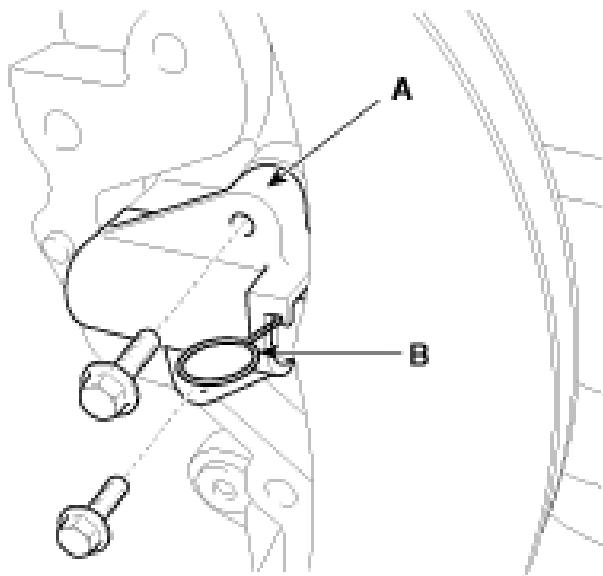

When reinstall the tensioner, check the ratchet function of the tensioner after removing the fixing pin by retracting the tensioner arm (A) maximally as shown below. When maximally retracted, there should be no interference between the tensioner arm (A) and tensioner housing (B).

- When reinstall the tensioner, check the ratchet function of the tensioner after removing the fixing pin by retracting the tensioner arm (A) maximally as shown below.
- When maximally retracted, there should be no interference between the tensioner arm (A) and tensioner housing (B).

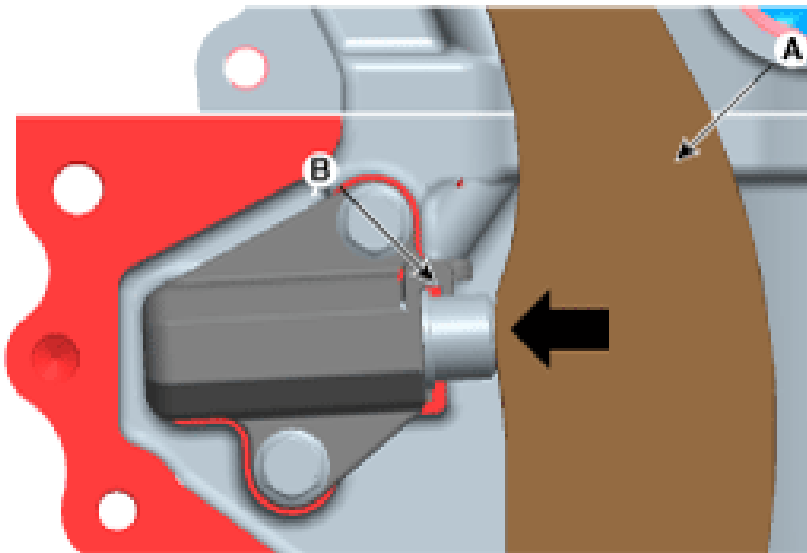

- After rotating crankshaft 2 revolutions in regular direction (clockwise viewed from front), confirm that the TDC marks on the intake and exhaust CVVT sprockets are aligned with the top surface of cylinder head.
 - Install the other parts reverse order of removal.
- Refill engine with engine oil. Clean battery posts and cable terminals and assemble. Inspect for fuel leakage. After assembling the fuel line, turn on the ignition switch (do not operate the starter) so that the fuel pump runs for approximately two seconds and fuel line pressurizes. Repeat this operation two or three times, then check for fuel leakage at any point in the fuel line.
- Refill engine with engine oil.
 - Clean battery posts and cable terminals and assemble.
 - Inspect for fuel leakage.
 - After assembling the fuel line, turn on the ignition switch (do not operate the starter) so that the fuel

pump runs for approximately two seconds and fuel line pressurizes.

- Repeat this operation two or three times, then check for fuel leakage at any point in the fuel line.