

Component Procedures: Drive Belt

Table of Contents

1. Parts and Labor (itype_189)
2. Drive Belt - Repair Procedures (Article 45326)

Component Procedures: Drive Belt

Parts and Labor (itype_189)

Parts

Qualifier	Part #	Name	Price	Note
Belts & Pulleys	252122E300	Serpentine Belt	45.10	

Labor

Operation	Qualifier Path	Skill	Std Hrs	Wty Hrs
Remove & Replace	Belts & Pulleys > Serpentine Belt, R&R	C	0.4	0.0

Drive Belt - Repair Procedures (Article 45326)

- Removal
- Remove the drive belt . Using the wrench, turning the drive belt tensioner (A) counterclockwise. Disconnect the drive belt (A). Remove the drive belt tensioner (A) and then remove the drive belt (B).
- Using the wrench, turning the drive belt tensioner (A) counterclockwise.

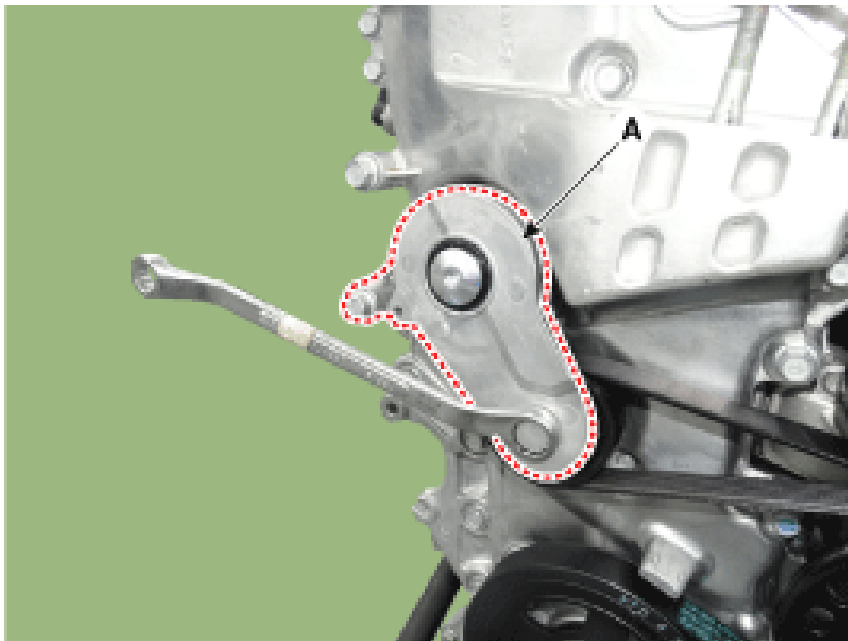

- Disconnect the drive belt (A).

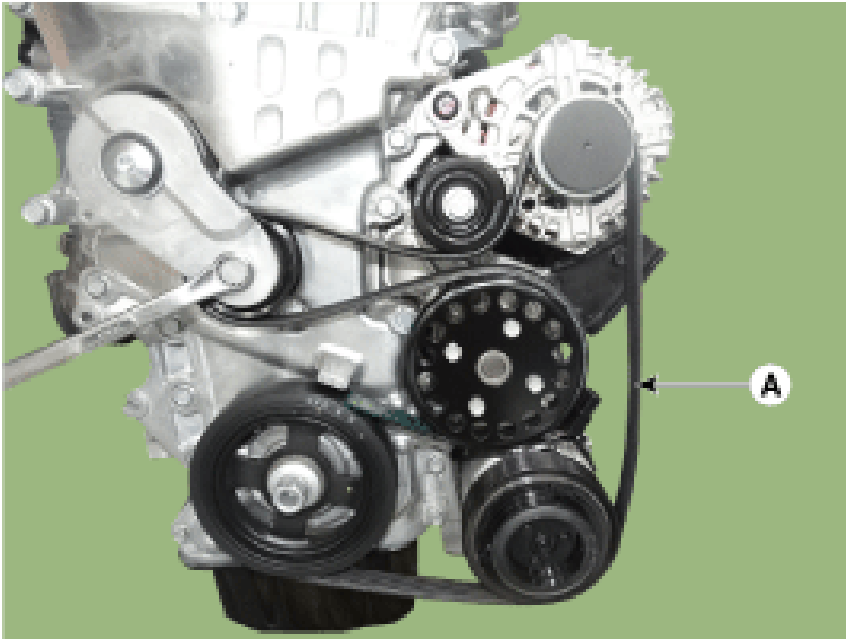

- Remove the drive belt tensioner (A) and then remove the drive belt (B).

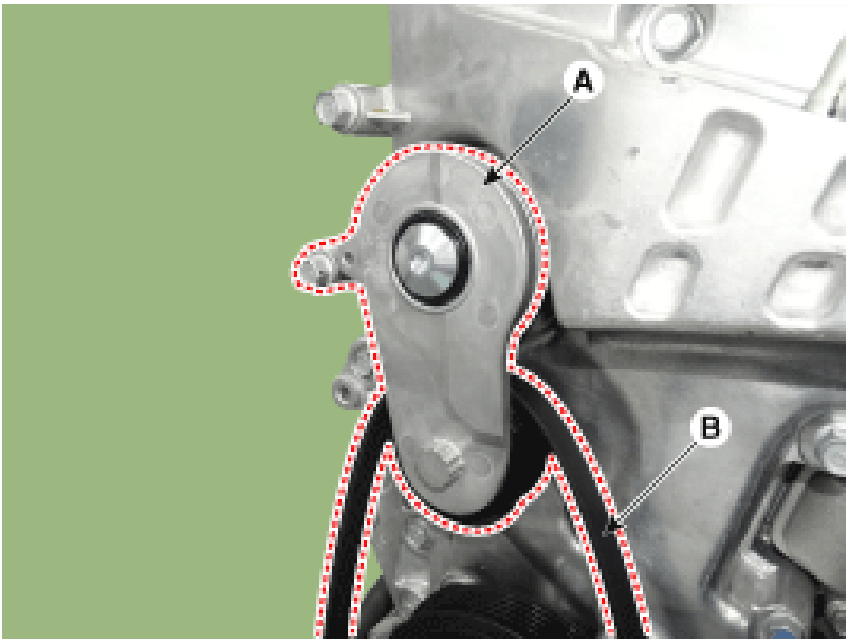

- Inspection
- Check belt for maintenance and abnormal wear of V-ribbed part. Replace if necessary. Do not bend, twist or turn the drive belt inside out. Do not allow the drive belt to come into contact with oil, water and steam.
Do not bend, twist or turn the drive belt inside out. Do not allow the drive belt to come into contact with oil, water and steam.

NOTICE

- Do not bend, twist or turn the drive belt inside out.
- Do not allow the drive belt to come into contact with oil, water and steam.

- Visually check the belt for excessive wear, frayed cords etc. If any defect has been found, replace the drive belt. Cracks on the rib side of a belt are considered acceptable. If the belt has chunks missing from the ribs, it should be replaced.
- Cracks on the rib side of a belt are considered acceptable. If the belt has chunks missing from the ribs, it should be replaced.
- Cracks on the rib side of a belt are considered acceptable. If the belt has chunks missing from the ribs, it should be replaced.

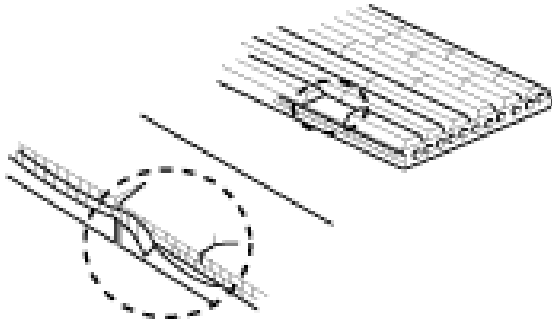

Drive belt tension measurement and adjustment

Belt tension measurement

If the engine has run for 5 minutes or more, the belt tension must be adjusted as a used belt. When installing the V-ribbed belt, all grooves on the pulley should be covered with belt ribs. A loose belt causes slip noise. Too tight belt cause bearing of alternator and water pump to damage.

- If the engine has run for 5 minutes or more, the belt tension must be adjusted as a used belt.
- When installing the V-ribbed belt, all grooves on the pulley should be covered with belt ribs.
- A loose belt causes slip noise.
- Too tight belt cause bearing of alternator and water pump to damage.

Using a mechanical tension gauge (BT-33-73F, BTG-2 type)

- While pressing the handle (A) of the gauge, insert the belt (B) between pulley and pulley (or idler) into the gap between spindle (C) and hook (D).

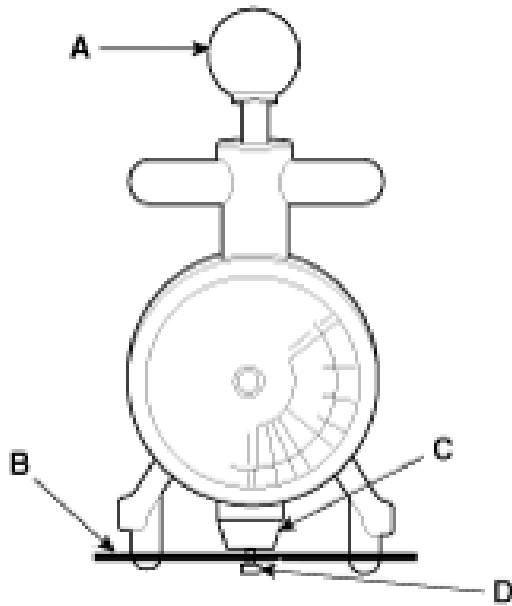

- After releasing the handle (A), read a value on the dial pointed by the indicator (B).

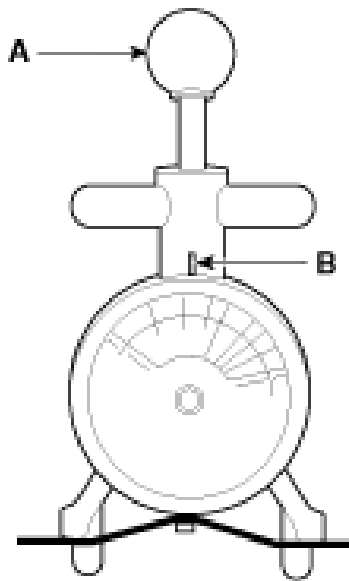

Using a sonic tension meter (U-505/507 type)

- Input the belt specifications into the tension meter (A). Belt type Location of measurement Input data M (Mass, g/m.rib) W (Width, rib) S (Span, mm) With A/C Crankshaft pulley to A/C compressor pulley 14.1 006.0 187 Without A/C Crankshaft pulley to alternator pulley 14.1 006.0 Actual measurement value Measurement of S (Span) : Caculate average value after measuring the distance 3-4 times.

Belt type Location of measurement Input data M (Mass, g/m.rib) W (Width, rib) S (Span, mm)

With A/C Crankshaft pulley to A/C compressor pulley 14.1 006.0 187

Without A/C Crankshaft pulley to alternator pulley 14.1 006.0 Actual measurement value

Measurement of S (Span) : Caculate average value after measuring the distance 3-4 times.

- Measurement of S (Span) : Caculate average value after measuring the distance 3-4 times.

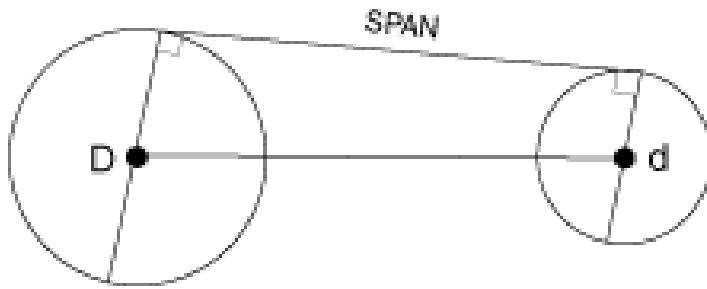

D : Crankshaft pulley diameter [147 mm (5.79 in.)]

d : Alternator pulley diameter [58 mm (2.28 in.)]

X : Distance of center

$$\text{SPAN} = \sqrt{X^2 - \frac{(D-d)^2}{4}}$$



- Locate the microphone (B) close to the center of belt span (A) and bounce the belt by finger 2-3 times.

Read a value on the display. [With A/C] [Without A/C]

[With A/C]

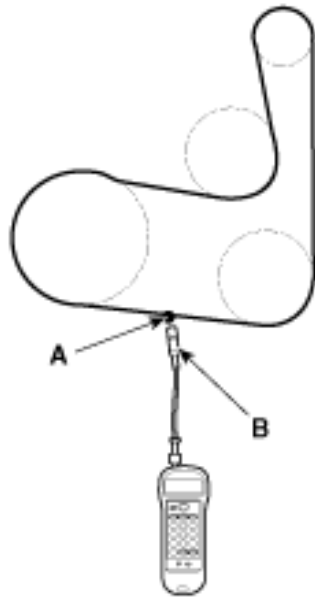

[Without A/C]

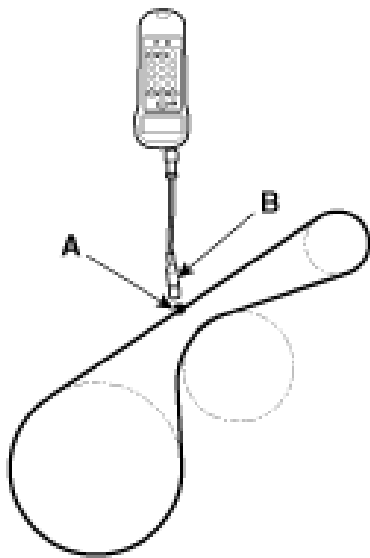

- Installation

- Install the drive belt. Install the drive belt (B) and then install the drive belt tensioner (A). Tightening torque center bolt : 29.4 - 41.2 N.m (3.0 - 4.2 kgf.m, 21.7 - 30.4 lb-ft) fixing bolt : 39.2 - 49.0 N.m (4.0 - 5.0 kgf.m, 28.9 - 36.2 lb-ft) Using the wrench, turning the drive belt tensioner (A) counterclockwise. Connect the drive belt (A). Remove the wrench.
- Install the drive belt (B) and then install the drive belt tensioner (A). Tightening torque center bolt : 29.4 - 41.2 N.m (3.0 - 4.2 kgf.m, 21.7 - 30.4 lb-ft) fixing bolt : 39.2 - 49.0 N.m (4.0 - 5.0 kgf.m, 28.9 - 36.2 lb-ft)
- Connect the drive belt (A).
- Remove the wrench.